

# PULSAFEEDER

## THREAD MOUNT MIXER

The thread mount mixer provides a simple means of mounting smaller mixers onto tanks or drums with a bung hole in the cover. Thread mounts feature a 2" nipple which screws directly into a standard bung, cutting labor and cost by eliminating the need for drilling mounting holes or providing additional mixer supports. Thread mount mixers are available with 1/3 HP, 115V, open and 1/20 HP, 115V, TEFC motors. The thread mount holds the mixer securely in a vertical position.

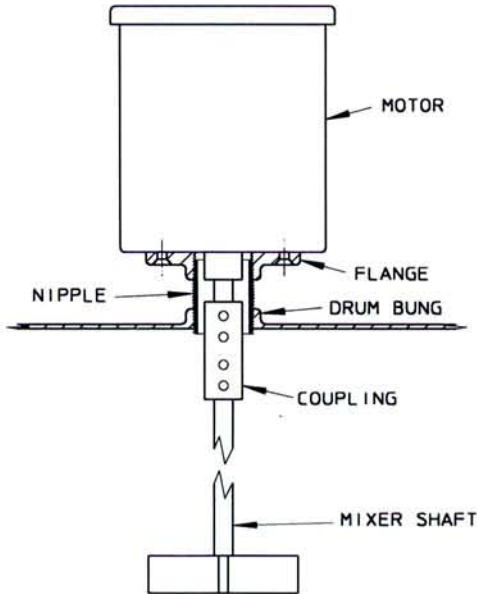

### CONSTRUCTION

All mixers feature a 316 stainless steel shaft with an integral impeller. Special epoxy and vinyl shaft coatings are available for applications where the solution being agitated is not compatible with 316 stainless steel. The shaft is coupled to the motor via a brass adapter which is held securely by four stainless steel set screws.

The thread mount adapters are of iron construction and have a corrosion resistant coating.

### MOUNT DETAIL

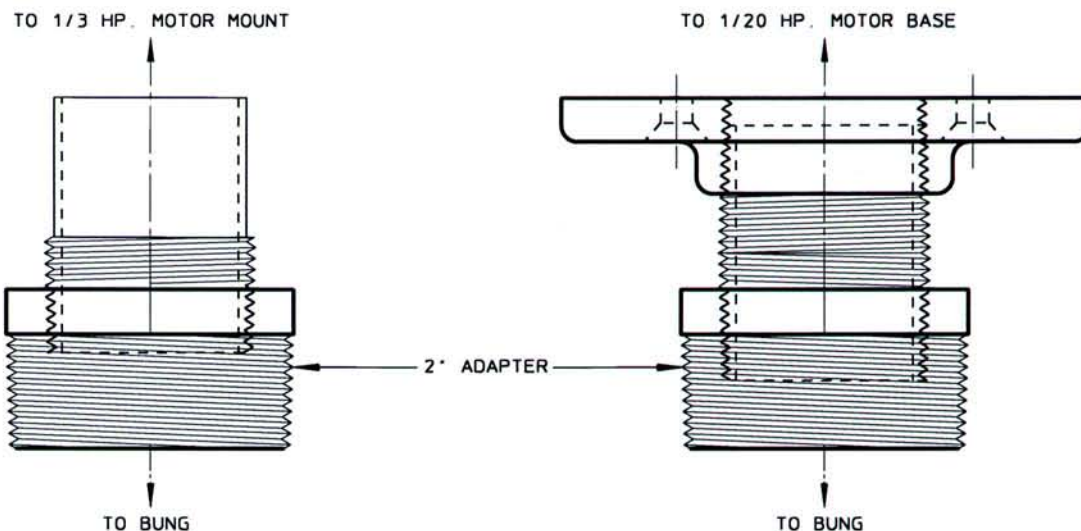

### INSTALLATION

Ensure the location of the mixer will allow sufficient clearance between impeller and tank walls. Insert mixer assembly into bung and tighten. Installation is complete.

# SPECIFICATIONS

Horsepower	1/3	1/20
RPM	1725	1500
Type	Open Drip Proof	Totally Enclosed Fan Cooled
Voltage	115 only	115 only
Amperage	5.9	1.9
Motor Design	- split phase - sleeve bearings	- split phase - ball bearings - non ventilated
*Shaft Length Diameter	36"	28"

\* Shafts may be cut to length upon request

# CONFIGURATION

Position      1            2            3            4            5

EXAMPLE MODEL #    T    2    0    H / WRD

Position 1 Mount

	REF#
Thread	T

Position 3 Motor Type

	REF#
Open Drip Proof*	0
Totally Enclosed Fan Cooled**	TE

Position 5 Options

	REF#
Suction Tube Shield Assy. 1" PVC Tube prevents suction tubing from entangling with mixer blade	29' 55 gal. 28655 20' 35 gal. 28656
6 ft., 3 wire, 18 gauge SJ cord and plug installed at factory	WRD
Special epoxy corrosion resistant coating for stainless steel shaft	EPOXY
Special vinyl corrosion resistant coating for stainless steel shaft (recommended for chlorine)	VINYL
230V Motor	230

Position 2 Horsepower

	REF#
1/20	M
1/3	2

\* 1/3 HP Only  
\*\* 1/20 HP Only

Position 4 Shaft

	REF#
316 Stainless Steel	H

J31557  
GB035  
10/94