

# PULSAFEEDER

## SERIES 8000 TANK SYSTEM

The Series 8000 Tank System, with its rugged construction, is designed for industrial applications requiring large tank and pump configurations.

### KEY FEATURES:

- Tanks and covers are constructed of high density translucent PE.
- Tank stands are constructed of heavy gauge steel with a black corrosion resistant finish.
- Space conserving base for pump mounting under tank - prevents loss of prime by maintaining a flooded suction.
- Completely piped with PVC bulkhead, ball valve, Y-strainer and suction tubing.
- Tanks feature graduated increments in both U.S. gallons and liters.

### OPTIONS:

- Top support ring for mounting of mixer to tank stand. (Bracket mount mixers recommended)
- 316 S.S. hinged lid for easier chemical replenishment.

**Note:** Some model pumps may be installed on base prior to shipping. Contact factory for details.

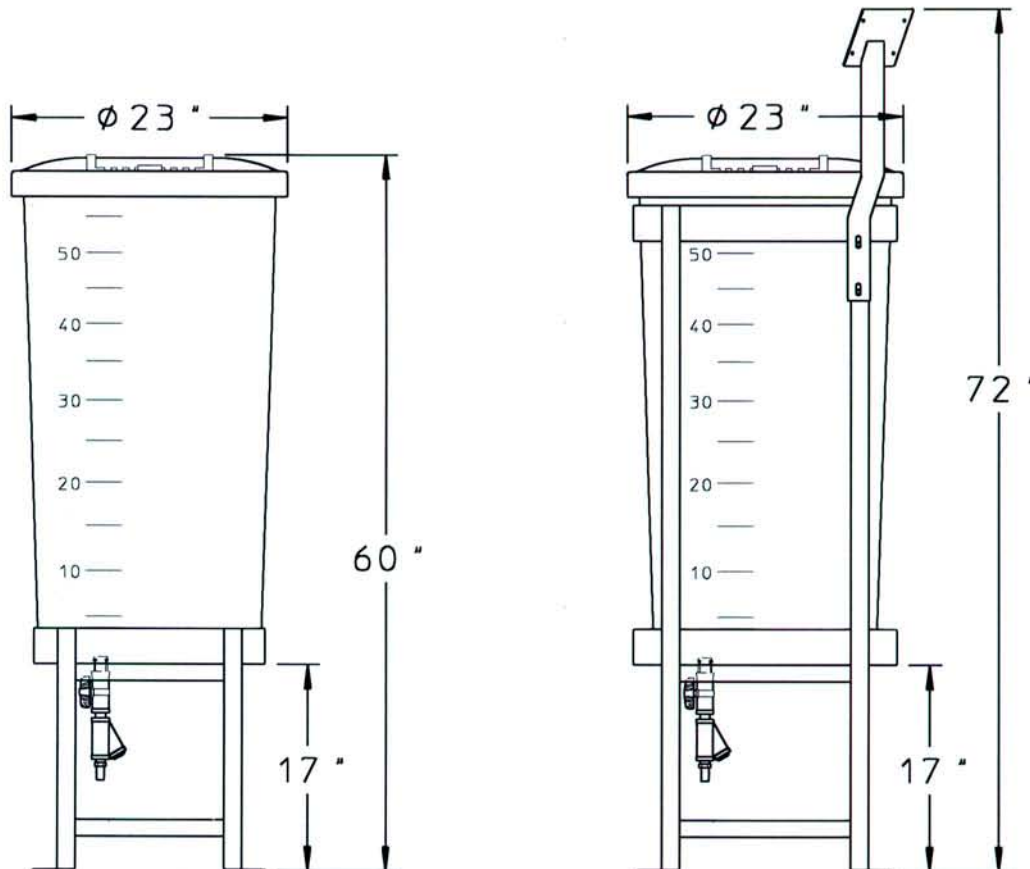

SIZE	STANDARD MODEL	TSR MODEL (TOP SUPPORT RING)	STD. MODEL with HINGED LID	TSR MODEL with HINGED LID	TANK WALL THICKNESS
50-gal	40396	40421	J40461	J40455	.13"

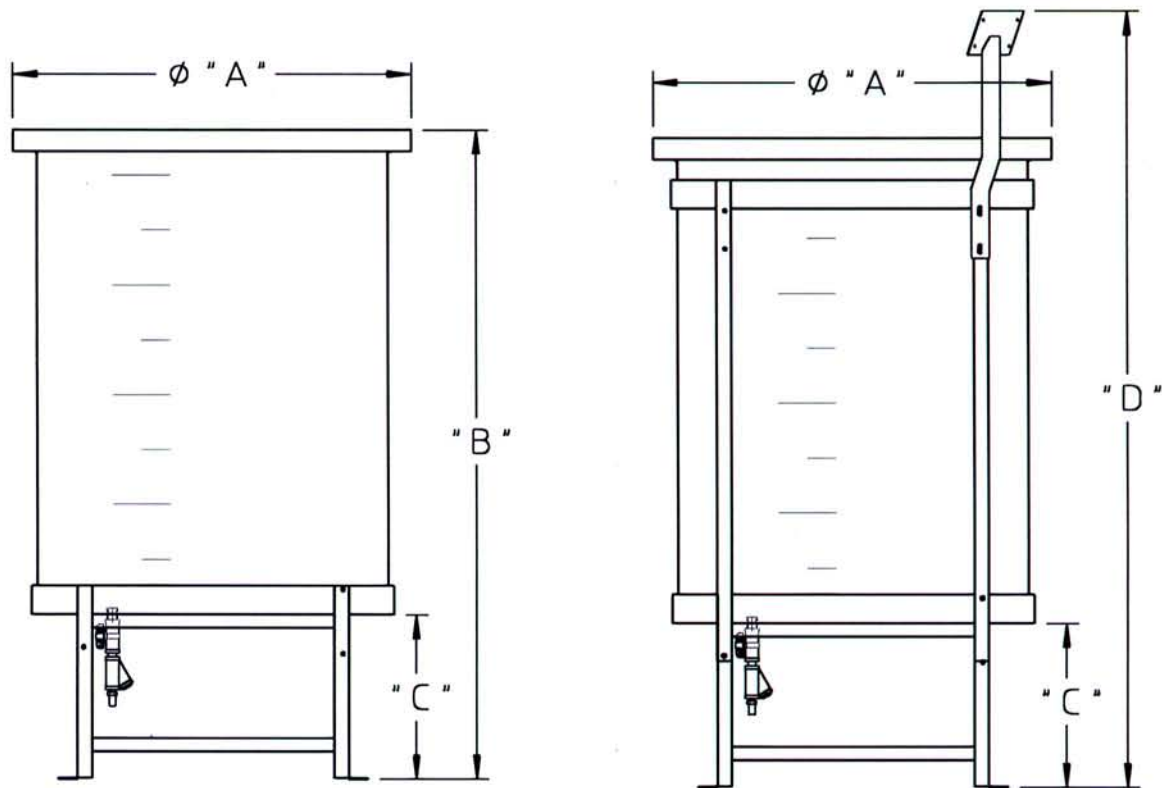

NOTE: TANKS PICTURED ABOVE ARE FOR SHAPE/DIMENSION REFERENCE, THEREFORE GRADUATIONS ARE LEFT UNMARKED. ACTUAL TANKS HAVE MARKED GRADUATIONS.

SIZE	STANDARD MODEL	TSR MODEL (TOP SUPPORT RING)	STD. MODEL with HINGED LID	TSR MODEL with HINGED LID	TANK WALL THK.	DIMENSIONS (inches)			
						DIM. 'A'	DIM. 'B'	DIM. 'C'	DIM. 'D'
100-gal	40397	40422	J40475	J40448	.25"	$\phi 33$	63	17	70
150-gal	40398	40423	J40476	J40477	.31"	$\phi 37$	68	17	82
200-gal	40399	40424	J40453	J40436	.31"	$\phi 42$	68	17	82

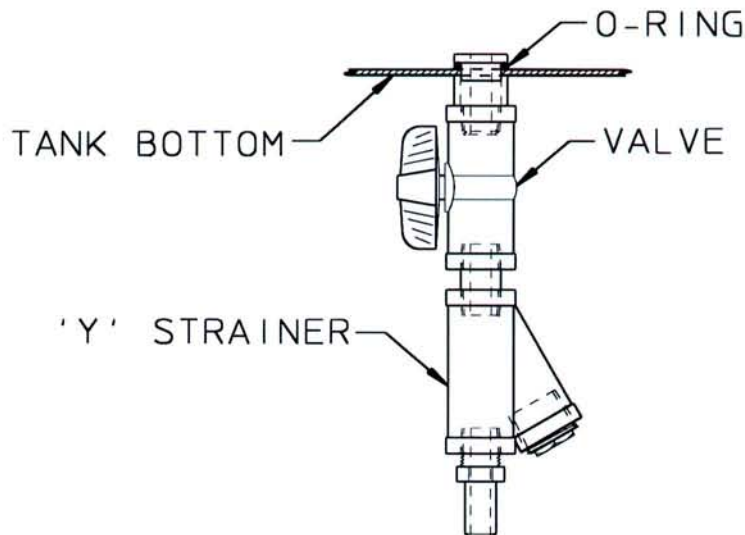

## PLUMBING DETAIL