



Metering Pump Controller



The MPC, Metering Pump Controller, expands the flow range capability of the PULSAR, Pulsar HypoPump, Shadow, Shadow HypoPump, Series M, and OMNI model pumps. The MPC is a speed based control system for automatic control with an analog input signal and manual control either at the pump or up to 1000 feet (304 meters) from the pump with the MPC's exclusive handheld keypad.

KEY FEATURES:

- Detachable handheld keypad with 4.5 feet (1.3 m) of cable as standard
- Handheld keypad can be mounted up to 1000 feet (304 m) from pump
- 1000:1 Turndown for wide range of flow (flows are always based on 60hz)
- Motor on/off control on the handheld keypad with high visibility red button
- UL and CSA Approval pending, CE Approved
- Uses a commercially available inverter rated motor
[Standard Motor is not NEMA 4X (IP56)]
- Displays pump output in units of flow (GPH or LPH)*
- NEMA 4X (IP56) rating on both pump mounted and handheld keypad enclosures [Requires different rated motor]
- Stroke length indication on the controller display*
- Automatic re-calibration of the pump curve with manual changes in stroke length*
- Security code to lock out unauthorized users
- Designed with safety and ergonomics in mind

Feature Performance Comparison:

Feature	MPC	Competition	DC Drive	AC Drive	Vector
NEMA 4X Enclosure (minimum IP56)	X		X	X	X
Typical Turndown	1000:1	90:1	20:1	10:1	100:1
CSA Approval and UL Approval pending	X		Optional	Optional	Optional
On Board Pump and Process System Diagnostics	X	X			
Simple Flow & Signal Calibration Routine	X	X			
Keypad with Liquid Crystal Display	X	X		X	X
Single Function Auto/Manual Switch	X		X	X	X
Motor ON/OFF Control at Pump	X	X			
Memory of Settings	X	X		X	X
Alarm Outputs	X	X		Optional	Optional
Uses a Motor Requiring No Maintenance	X	X		X	X
Factory Calibration of Flow w/ Flow Indication at Pump	X	X			
Auto Re-Calibration of Flow if Manual Stroke Length Control Changes	X				
CE Mark Standard	X	X	Optional	Optional	Optional
Modular for Field Convert from Pump Mount to Wall Mount Controls	X				

Technical Specifications:

Power Input Options	Single Phase, 115 or 230VAC (50 or 60 hz)
Analog Input/Output	One of each, Range is 4-20mA
Digital Inputs	(Two) Powered (up to 24V) or Non-powered solid-state contacts - User configurable
Digital Outputs	(Three) Non-powered solid-state contacts - User configurable
Rated Ambient Temperature	0 - 40° C
Steady State Accuracy	±1% over a 3:1 speed turndown ±2% over a 1000:1 speed turndown

Typical Dimensions: All Pulsar Series

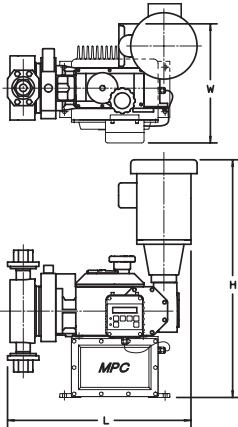

DIM	MODEL 25		MODEL 55	
	INCH	MM	INCH	MM
L	21.3	542.1	22.0	559.8
W	12.8	325.1	12.8	325.1
H	33.5	851.3	33.5	851.3
APPROX SHIP WT.	146LBS	66.2Kg	161LBS	73Kg



The MPC Handheld has remote capabilities of up to 1000 feet (304m) and can be mounted in safe and easily accessible environments. The backlit display allows for easy reading and can be programmed for english or metric measurements. Flow is indicated in relation to the pump and manual calculations are no longer required.

Typical Dimensions: OMNI

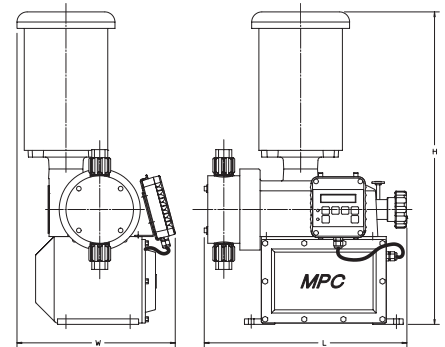

	L	H	W	WEIGHT
INCHES	15.50	23.50	12.00	66 LBS.
CENTIMETERS	39.37	59.69	30.48	30 KGS

PULSAFEEDER
A Unit of IDEX Corporation



NOVA-TECH
INTERNATIONAL

800 Rockmead Dr Ste 102 • Houston, TX 77339-2496
Tel: (281) 359-8538 • Toll Free Tel: (866) 433-6682
Fax: (281) 359-0084 • Toll Free Fax: (866) 433-6684
sales@novatech-usa.com • www.novatech-usa.com



MPC-TS 06/04