

IN-LINE ANTI-SIPHON VALVE

READ THIS FIRST

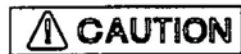

WHEN WORKING WITH CHEMICALS and/or CHEMICAL HANDLING EQUIPMENT, ALWAYS FOLLOW ALL SAFETY INSTRUCTIONS & PROCEDURES RECOMMENDED BY THE CHEMICAL MANUFACTURER, AS WELL AS THOSE RECOMMENDED BY THE EQUIPMENT MANUFACTURER, PROTECTIVE CLOTHING & EYE PROTECTION ARE AN ABSOLUTE MINIMUM REQUIREMENT.

DISCONNECT or TURN OFF POWER TO PUMPS, THEN DEPRESSURIZE & DRAIN SYSTEM. CLEAN UP & DISPOSAL OF ANY SPILLAGE & WASTE SHOULD BE IN ACCORDANCE TO CHEMICAL MANUFACTURERS SPECIFICATIONS, AND IS THE USERS RESPONSIBILITY.

THE ANTI-SIPHON VALVE IS TO BE LOCATED IN THE DISCHARGE LINE FROM THE FEEDER. SELECT THE LOCATION WHERE YOU WANT IT INSTALLED & CUT THE DISCHARGE LINE AT THAT POINT, MAKING SURE THE CUT IS PERPENDICULAR ACROSS THE TUBING.

REMOVE COMPRESSION NUTS FROM EACH END OF ANTI-SIPHON VALVE & SLIDE ONE ONTO EACH END OF THE TUBING YOU JUST CUT.

PUSH ONE END OF THE CUT TUBING ONTO EITHER END OF ANTI-SIPHON VALVE. NOTE: ANTI-SIPHON VALVE HAS BEEN DESIGNED SO THAT IT FUNCTIONS EQUALLY WELL, REGARDLESS OF THE DIRECTION IN WHICH IT IS INSTALLED.

PUSH THE OTHER END OF CUT TUBING ONTO THE OPPOSITE END OF THE ANTI-SIPHON VALVE. NOTE: TUBING WILL SLIDE ONTO ANTI-SIPHON VALVE EASIER IF YOU IMMERSE THE END OF TUBING IN HOT WATER FIRST. TUBING MUST BE PUSHED ALL THE WAY ONTO FITTING, UNTIL IT 'BOTTOMS OUT' AGAINST THREAD SHOULDER, AS SHOWN.

SLIDE THE COMPRESSION NUTS UP TUBING & THREAD THEM ONTO BOTH ENDS OF THE ANTI-SIPHON VALVE.

INSPECT & CLEAN or REPLACE ANIT-SIPHON VALVE AT REGULAR INTERVALS.

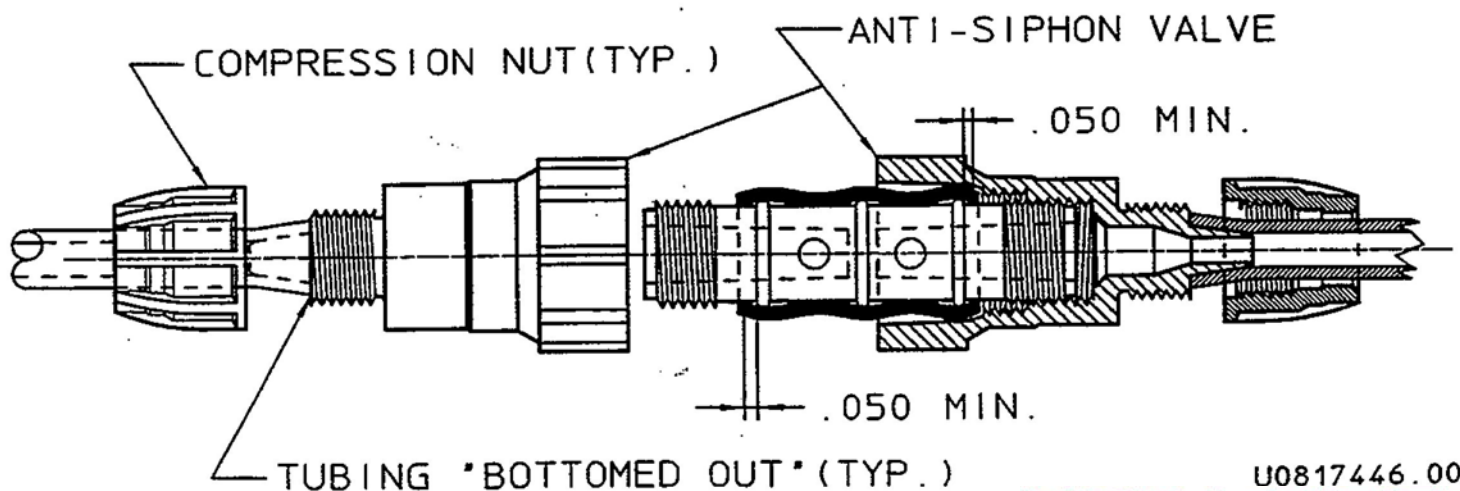

U0817446.001

NOVA-TECH
INTERNATIONAL

800 Rockmead Dr Ste 102 • Houston, TX 77339-2112
Tel: (281) 359-8538 • Toll Free Tel: (866) 433-6682
Fax: (281) 359-0084 • Toll Free Fax: (866) 433-6684
sales@novatech-usa.com • www.novatech-usa.com