

# Bracket Mount Mixer



## The Bracket Mount Mixer

provides a means of mounting a mixer to a tank cover or other flat surface. Four 18/8 stainless steel bolts and two rugged 3/8" thick steel brackets hold the mixer securely in place, requiring no additional mixer supports.

**Construction:** All mixers feature a 316 stainless steel shaft with an integral impeller (dual impellers standard on 48" shafts). Special epoxy and vinyl shaft coatings are available for applications where the solution being agitated is not compatible with 316 stainless steel. The shaft is coupled to the motor via a brass adapter which is held securely by four stainless steel set screws.

The mounting bracket is constructed of steel with a corrosion resistant coating and all fasteners are 18/8 stainless steel.



## Installation:

**For use without mixer support:** Measure the impeller diameter and cut a hole of the appropriate size in the tank lid. Hole should be located so mixer shaft does not make contact with tank wall. Next place the motor (with brackets attached) so that the shaft is centered over the hole that was drilled in the proceeding step. Using the bracket holes as a guide, mark the tank cover. Remove mixer assembly. Drill holes large enough for the fasteners in the four marked locations. Reinstall the mixer assembly and fasten securely to the tank cover with the four bolts provided.

## Mounting with top support ring:

When the Tank System is ordered with a top support ring (TSR), a mounting plate is provided for the bracket mount mixer. The bracket assemblies are removed and the motor mounts directly to the mounting plate of the top support ring. Cut hole in tank lid to accommodate the mixer shaft.

technology  
innovation  
diversity  
excellence

# Bracket Mount Mixer Specifications

Bracket Mount Mixer Selection Guide	
<b>MOUNT:</b>	<b>B</b> = Bracket Mount Mixer
<b>HORSEPOWER:</b>	<b>M</b> = 1/20 <b>1</b> = 1/4 <b>2</b> = 1/3 <b>3</b> = 1/2 <b>4</b> = 1
<b>TYPE:</b>	<b>0</b> = Open Drip Proof <b>TE</b> = Totally Enclosed Fan Cooled <b>EXP</b> = Explosion Proof
<b>SHAFT:</b>	<b>H</b> = 316 Stainless Steel
<b>AVAILABLE OPTIONS:</b>	<b>WRD</b> = 6' 3 wire 18 gauge SJ cord and plug installed at factory <b>EPOXY</b> = Special epoxy corrosion resistant coating for stainless steel impeller and shaft <b>VINYL</b> = Special vinyl corrosion resistant coating for stainless steel impeller and shaft recommended for sodium hypochlorite <b>230</b> = 230V Motor <b>Suction Tube Shield Assembly. 1" PVC tube, prevents pump suctiontubing from entangling with mixer blade.</b> <b>28655</b> = 29" - 55 gallon <b>28656</b> = 20" - 35 gallon
A completed model number should look like 'B-3-TE-H/VINYL'	

## Specifications

Type	OPEN				TOTALLY ENCLOSED								EXPLOSION PROOF												
	34	36	44	48	28	34	36	44	48	34	36	44	48												
<b>Shaft Length*</b>	34	36	44	48	28	34	36	44	48	34	36	44	48												
<b>Horsepower</b>	1/4	1/3	1/2	1	1/20	1/4	1/3	1/2	1	1/4	1/3	1/2	1												
<b>RPM</b>	1725				1500	1725																			
<b>Voltage</b>	115	250	115	230	115	230	115	230	115	230	115	230	115	230	115	230	115	230	115	230	115	230	115	230	
<b>Amperage**</b>	6.2	3.1	6.8	3.4	8.2	4.1	14.8	7.4	2.0	5.2	2.6	6.8	3.4	9.6	4.8	13.6	6.8	4.5	2.3	6.8	3.4	9.0	4.5	13.6	6.8
<b>Motor Design</b>	- split phase - sleeve bearings  1 HP motors - capacitor start				1/20 HP Motors - ball bearing - shaded pole - fan cooled  All Other Motors - ball bearing - automatic overload - capacitor start - fan cooled								- split phase - ball bearing - non ventilated  1 HP Motors - automatic overload - capacitor start - fan cooled												

## Dimensions

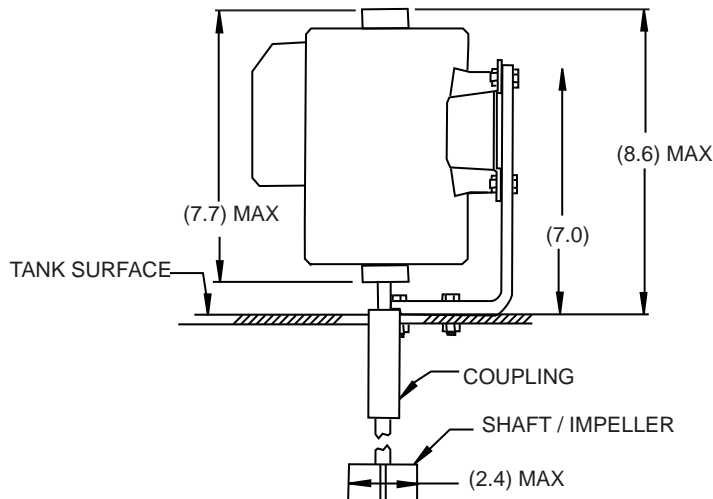

An ISO Certified Company

**PULSAFEEDER®**

A Unit of IDEX Corporation

**IDEX**  
 IDEX CORPORATION  
 GB032 D09

**NOVA-TECH**  
 INTERNATIONAL  
 800 Rockmead Dr Ste 102 • Houston, TX 77339-2496  
 Tel: (281) 359-8538 • Toll Free Tel: (866) 433-6682  
 Fax: (281) 359-0084 • Toll Free Fax: (866) 433-6684  
 sales@novatech-usa.com • www.novatech-usa.com