

DCS 900 Series

COOLING TOWER CONTROL SYSTEMS

PULSAFEEDER
A Unit of IDEX Corporation

DCS 900 Series Cooling Tower Controller

Principle of Operation

The DCS 900 controller is designed to control conductivity and feed inhibitor in open-air cooling towers and closed loop systems. It measures the conductivity of the recirculating water and activates a 'bleed' relay output (typically attached to a solenoid activated blow down valve) when it exceeds a set point value. A second relay (typically attached to a chemical metering pump) is activated to feed inhibitor into the tower.

Two Models Available

DCS 901 - Timer version. The inhibitor relay is activated by the user configurable selectable timer (limit, percent or percent post bleed). The timer provides protection from overfeed by limiting the time that the inhibitor feed relay will remain active.

DCS 902 - Water Meter version. In addition to the selectable timer feature, the inhibitor relay can also be activated by pulse input generated from a water meter. Water meter input can be user configured for standard dry contact or hall effect.

Operating Benefits

- **4-electrode conductivity sensor.** New electrode technology enhances the accuracy and stability of the conductivity measurement providing a greater level of control within your application.
- **DIN Connections.** Sensor and water meter input connections utilize an IP 67 rated DIN connector, eliminating the need to access the internal electronics during installation.
- **Easy to Program User Interface.** Simply press the universally recognized symbol key identifying the function you wish to adjust and change the value with the up or down key.
- **Standard Flow Switch.** All systems include a flow switch that protects your system from feeding chemicals in the event of a loss of flow.
- **Optional Panel Assembly.** Select the mounted flow assembly and the entire controller and flow assembly comes conveniently mounted onto a rugged polyethylene panel for easy installation.

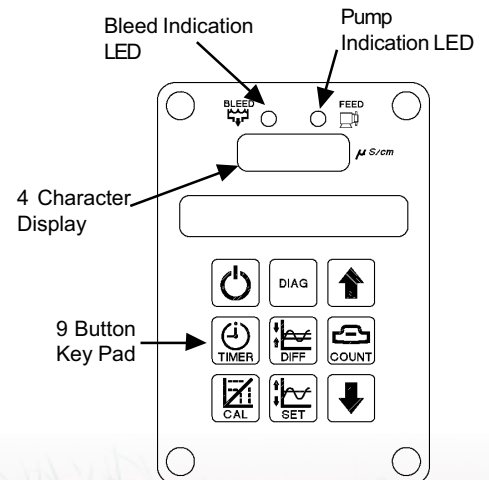

For additional information about the DCS 900 Series and available options see the Water Treatment List Price Schedule.

technology
innovation diversity
excellence

IDEX
IDEX CORPORATION

<http://www.novatech-usa.com/Products/Process-Control-Instrumentation>

Tel: (281) 359-8538 Toll Free: (866) 433-6682

DCS 900 Series Cooling Tower Controller Specifications

Unit Power:

- Operating voltage: 120 or 240 VAC +/- 10%, 5AMP's maximum
- Protection, Fuse: 250VAC, 5A Slo-Blow removable
- Cordage: 8' length 16AWG 3-wire domestic 120 VAC power cord set

High Voltage Output (Bleed & Feed (Pump) Relays):

- Operating Voltage: Same as supplied to unit
- Capacity: 4AMP fused output at 110VAC
- Protection: Fused
- Status: Normally Open
- Cordage: 2 Pigtails

Analog Input (Conductivity):

- Sensor: 4-electrode cell with 10' cord length and 3/4" Tee (threaded)
- Sensor Connector: 8-pin DIN connector
- Operating Range: 0-6000 μ S/cm (Temperature Compensated)
Unit will read: 0 - 4000 μ S/cm at 100°C
0 - 5000 μ S/cm at 75°C
0 - 9999 μ S/cm at 25°C
- Isolation: Isolated from Earth Ground only

Flow Input:

- Input Type: Isolated Dry Contact (5VDC supplied by controller)
- Sensor: Standard 2-pin DIN connector with 10 ft cable (18 in. cable on optional mounted flow assembly). Shorting jumper provided.

Water Meter Input: (DCS 902 only)

- Input Type: Open collector (sinking) isolated only. 5VDC and ground provided by connection
- Input Type: Dry Contact, can be configured to 125ms or 2ms open/closed operation.
- Sensor Connection: 8-pin DIN connector with 10 ft cable (3 ft cable on optional mounted flow assembly).

User Interface:

- Display: 4 Character LED (Red Characters)
- Feed LED: Green LED. Illuminated when the pump relay is on.
- Bleed LED: Green LED. Illuminated when the bleed relay is on.
- Keypad: Membrane style, 9 Keys: On/Standby, Up, Down and 6 Function Keys.

Enclosure:

- IP Rating: IP54 (Protected against dust and splashing water)
- NEMA Rating: Type 4X

Environment:

- Max Ambient Temp: 104°F (40°C)

Dimensions:

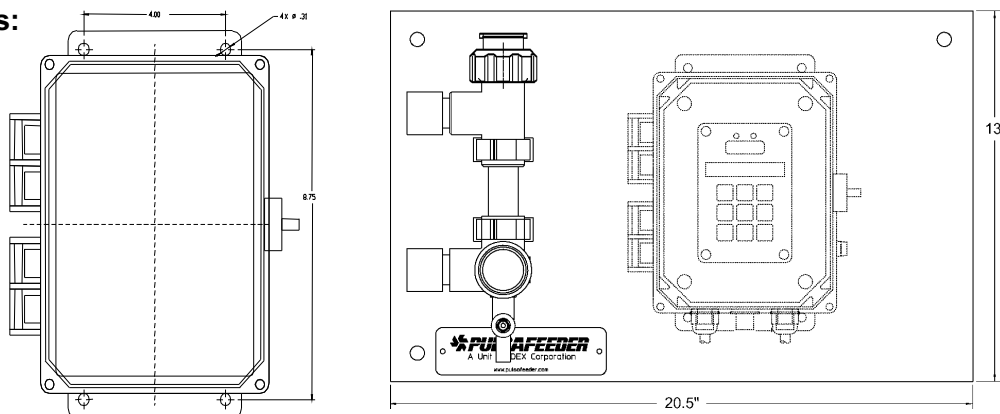

An ISO Certified Company

IDEX
IDEX CORPORATION

PULSAFEEDER[®]
A Unit of IDEX Corporation

NOVA-TECH
INTERNATIONAL
800 Rockmead Dr Ste 102 • Houston, TX 77339-2112
Tel: (281) 359-8538 • Toll Free Tel: (866) 433-6682
Fax: (281) 359-0084 • Toll Free Fax: (866) 433-6684
sales@novatech-usa.com • www.novatech-usa.com