

Instruction Manual

Temp 4/5/6

Temperature Meter Series



OAKTON®

**EUTECH
INSTRUMENTS**

Technology Made Easy...

68X243607

Rev. 4 May 06



Preface

This instruction manual serves to explain the use of the Temp 4/5/6 temperature meter.

It functions in two ways: first as a step by step guide to help you operate the meter; second, it serves as a handy reference guide.

This manual is written to cover as many anticipated applications of the Temp 4/5/6 meter as possible. If there are doubts in the use of this meter, please do not hesitate to contact the nearest Eutech Instruments/ Oakton Instruments Authorised Distributor.

Eutech Instruments/ Oakton Instruments will not accept any responsibility for damage or malfunction to the meter caused by improper use of the instrument.

The information presented in this manual is subjected to change without notice as improvements are made, and does not represent a commitment on the part of Eutech Instruments Pte Ltd/ Oakton Instruments.

Copyright © 1999

Eutech Instruments Pte Ltd/ Oakton Instruments

TABLE OF CONTENTS

<u>1. INTRODUCTION</u>	<u>1</u>
1.1 Introducing the economy series	1
<u>2. GETTING STARTED</u>	<u>2</u>
2.1 Description of Keypad Functions	2
2.2 Description of LCD Annunciators	2
2.3 Inserting & Removing the Rubber Boot	3
2.4 Inserting New Batteries	4
2.5 Battery Replacement	5
2.6 Connecting the Temperature Sensor	5
2.7 Switching the Meter On	6
<u>3. CALIBRATION</u>	<u>7</u>
3.1 Temperature Calibration	7
3.1.1 <i>Temperature Calibration using Offset Adjustment</i>	7
3.1.2 <i>Temperature Curve Selection (Temp 5 Meter Only)</i>	9
<u>4. MEASUREMENT</u>	<u>10</u>
4.1 Taking Measurements	10
4.2 Displaying Maximum and Minimum Readings	10
4.3 Holding a Reading	10
4.4 Releasing a Held Reading	11
4.5 Maximum and Minimum Hold Mode	11
<u>5. DISABLE AUTO POWER-OFF FEATURE</u>	<u>12</u>
<u>6. PROBE CARE AND MAINTENANCE</u>	<u>13</u>
<u>7. TROUBLESHOOTING</u>	<u>13</u>
<u>8. SPECIFICATIONS OF TEMP SERIES</u>	<u>14</u>
<u>9. ACCESSORIES</u>	<u>15</u>
<u>10. WARRANTY & RETURN OF ITEMS</u>	<u>16</u>
<u>11. RETURN OF ITEMS</u>	<u>17</u>

1. INTRODUCTION

1.1 *Introducing the economy series*

Thank you for purchasing the Temp 4/5/6 meter. These microprocessor-based handheld meters are economical and easy to use. They are available in three models:

- The Temp 4 uses *YSI 400 series thermistor temperature sensor
- The Temp 5 uses 100K thermistor temperature sensor
- The Temp 6 uses PT100 ohm (Platinum) RTD temperature sensor

All Temp 4/5/6 meter series feature:

- Large LCD for clear and easy reading
- Readings in °C and °F (selectable)
- Minimum and maximum temperature display
- Minimum and maximum hold mode
- Low battery indicator
- Hold function, freezes measured reading
- User calibration - offset adjustment
- Non volatile memory backup; calibration and other information remain if battery is disconnected
- Temp 5 meter allows user selection of most suitable temperature curve for its thermistor sensor

This instruction manual is organised for quick reference with step-by-step procedures that give you thorough review of the various features and meter operations.







Included with your meter are a temperature sensor (Temp 5 only), rubber boot, 4 alkaline “AAA” batteries, an instruction manual and a warranty card. To order other accessories, please refer to Section on Accessories for more information.

* YSI is a registered trademark of Yellow Springs Instruments.

2. GETTING STARTED

2.1 Description of Keypad Functions

Temp 4/5/6 meters have six keys on its splash-proof keypad. These keys include ON / OFF, CAL, HOLD / ENTER, °C/°F, MAX / ▲ (UP) and MIN / ▼ (DOWN) keys.

	ON/OFF: Powers meter ON or OFF. Meter directly enters measurement mode when you turn it on
	CAL: Allows temperature calibration of the meter.
	HOLD/ENTER: Freezes the measured reading; confirm calibration value.
 	MAX/▲ (UP) and MIN/▼ (DOWN): Momentarily displays meter's maximum and minimum temperature; enter maximum or minimum hold mode; scroll up and down in calibration mode.
	°C/°F: Switches between °C and °F in measurement mode.

2.2 Description of LCD Annunciators

The Temp 4/5/6 meters have a large custom LCD that consists of 4-digit segments and operation annunciators for °C and °F. Other indicators include "MIN", "MAX", "HO" (when the HOLD function is activated) and "LO" (low battery condition).

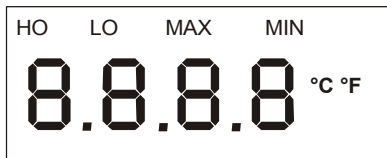

2.3 Inserting & Removing the Rubber Boot

1. To remove meter from rubber boot, push out from the bottom edges of meter until it is completely out of boot. Ensure that the connector of temperature sensor is not connected.
2. To insert meter into rubber boot, slide in from the top of meter before pushing the bottom edges of meter down to set it into position. Lift up the stand at the back of meter for bench top applications if necessary.

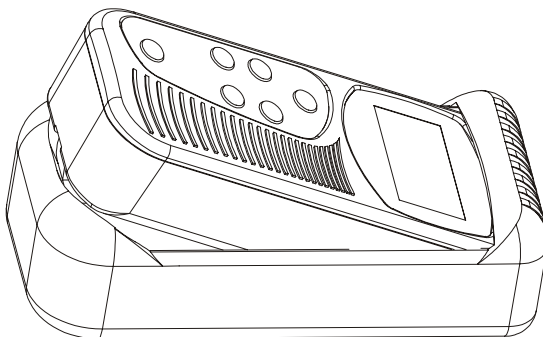

2.4 Inserting New Batteries

The battery compartment is found at the back of instrument. To open the battery compartment, push in the direction of arrow and lift up the cover. Note the polarity of battery before inserting into position. After replacement, place cover back and press down until it locks tight.

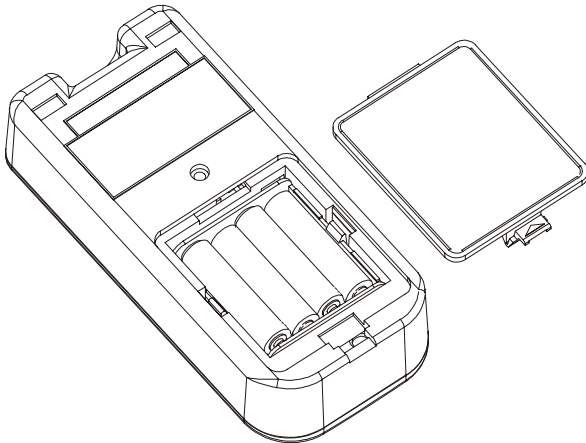

2.5 Battery Replacement

A “LO” annunciator in the LCD alerts you when battery power is running low. Replace with the same type as recommended by the manufacturer.

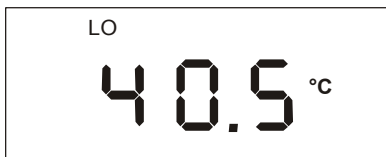

Caution: Power off the meter when changing battery.

2.6 Connecting the Temperature Sensor

To connect a temperature probe into the meter, align the connector of probe to the meter's socket and push fully until it is in position.

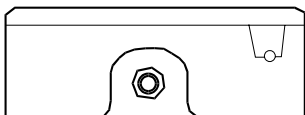

Temp 4/5 Socket

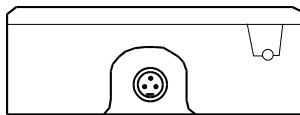

Temp 6 Socket

Note: Both the Temp 4/5 use phono jacks while the Temp 6 uses a 3-pin connector with a locking mechanism.

2.7 Switching the Meter On

1. Press **ON/OFF** key to power up your meter. All the LCD segments display momentarily as the meter performs a self-diagnostic test, per shown in section 2.2. The LCD then switches into measurement mode.
2. The LCD displays “**oPEn**” if the temperature sensor is faulty, or there is an open circuit. Please refer to section on Troubleshooting if in doubt.



3. CALIBRATION

3.1 Temperature Calibration

The temperature sensor included (only for Temp 5) with your meter is factory calibrated. Over time, the temperature calibration may drift and the probe requires recalibration. The Temp 4/5/6 meters allow you to have a 1-point calibration as fine adjustment by changing its offset value. This is useful if you replace the probe and should recalibrate the probe to the meter.

3.1.1 Temperature Calibration using Offset Adjustment

1. First connect the temperature probe to the meter. Press **ON/OFF** key to power up the meter and wait for meter to enter measurement mode.
2. Dip the probe in a constant temperature bath, or in liquid whose temperature can be checked with an accurate thermometer. For best accuracy, place the probe and thermometer in a constant temperature bath.
3. Wait for readings to stabilise.
4. To enter temperature calibration mode, press and hold **CAL** key for 5 seconds before release. The LCD shows "**CA**" momentarily and a value flashes.
5. Press **MAX/▲** or **MIN/▼** key to adjust the displayed value until it matches the correct temperature. The **MAX/▲** or **MIN/▼** key will scroll to the maximum allowable value.

NOTE: The maximum adjustments allowed are ± 5 °C from factory default.

6. Press **ENTER** key to confirm calibration.
7. The LCD displays “CO” momentarily, and the meter then reverts to measurement mode. See figure below.

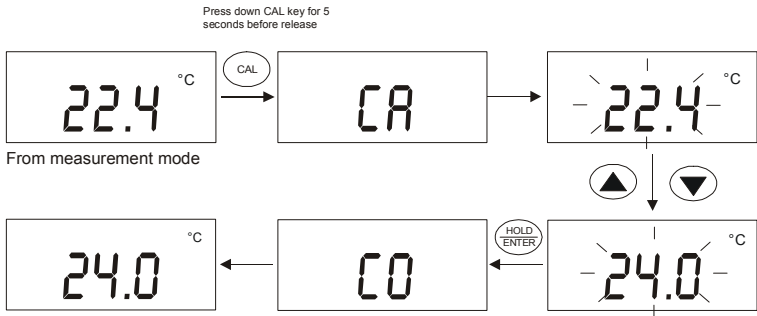

3.1.2 Temperature Curve Selection (Temp 5 Meter Only)

In the event temperature probe has drifted too far from its original characteristic – due to age and use or if the probe is being replaced, it may be a good idea to match probe to the best curve. There are 3 curves programmed in the unit. To choose the curve, proceed as follows:

1. Connect your temperature probe to the meter. Dip the probe in a constant temperature bath or a liquid whose temperature can be checked with a thermometer known to be accurate. For best accuracy, place the probe and thermometer in a constant temperature bath.
2. Turn on the meter. Make sure that the meter is in the measurement mode. Press **CAL** key for 5 seconds to enter calibration mode. The LCD shows “**CA**” and the reading flashes.
3. Press **°C/°F** key to enter curve selection mode. Press the **°C/°F** key again to scroll through three temperature curves (low, mid, high). Each press will take you through one curve. Choose the curve which gives you a reading closest to the actual value (of the bath or thermometer).
4. Press **ENTER** key and the curve selection is complete. The unit will display “**CO**” and revert to the temperature calibration mode, with the display still flashing.
5. Press **▲** and **▼** key to make fine adjustment until the display shows the correct desired temperature. The **▲** and **▼** key will scroll to the maximum allowable value (maximum adjustment is ± 5 °C from factory default).
6. Press **ENTER** key to confirm calibration. The LCD displays “**CO**” momentarily, and the meter then reverts to measurement mode.

4. MEASUREMENT

4.1 Taking Measurements

1. Power on the meter. The meter automatically enters Temperature mode. The °C or °F annunciator displays in your LCD to indicate which mode you are taking measurements in.
2. Press the °C/ °F key to toggle between each measurement mode.

4.2 Displaying Maximum and Minimum Readings

The EcoScan Temp meter can momentarily display the maximum and minimum temperature measured since you switched the meter on. Simply press **MAX/▲** or **MIN/ ▼** key. The “**MAX**” or “**MIN**” annunciator displays in the LCD and the maximum or minimum temperature momentarily displays. Meter then returns to measurement mode.



4.3 Holding a Reading

To freeze or hold your reading, press **HOLD** key once. The LCD displays "HO" annunciator to indicate the HOLD function is activated.



4.4 Releasing a Held Reading

Press **HOLD** key again to deactivate HOLD function or to release your frozen reading. The meter returns to measurement mode, and the “**HO**” annunciator disappears from the LCD.

4.5 Maximum and Minimum Hold Mode

With the Maximum and Minimum Hold Mode, the EcoScan Temp meter can be used as a maximum registering (or minimum registering) thermometer. The meter displays the lowest or highest temperature measured since entering the Maximum or Minimum Hold mode.

1. Power on the meter. The meter automatically enters Temperature mode. Use °C/°F key to switch between Celsius and Fahrenheit reading if desired.
2. Press **HOLD** key. The reading freezes and the annunciator “**HO**” displays in the LCD.
3. Press **MAX/▲** or **MIN/▼** key. Meter enters the Maximum or Minimum Hold mode. “**HO**” and “**MAX**” or “**MIN**” annunciator displays in the LCD.

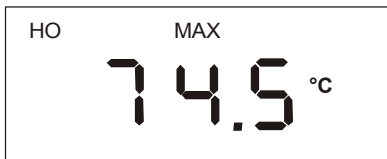

Meter will now continuously display the lowest or highest temperature measured since you entered this mode. It will update the display when new highs or lows are reached.

Press **HOLD** key again to leave MIN/MAX Hold mode and meter returns to its measurement mode.

5. DISABLE AUTO POWER-OFF FEATURE

By default this meter will auto power-off 17 minutes after last key operation. This is to conserve battery power. The auto power-off feature can be disabled in situation where longer periods of monitoring are desired.

NOTE: The meter switches back to auto power-off mode as soon as it is turned off.

Procedure:

1. With meter off, press down ON/OFF and MIN/▼ keys together.
2. Release ON/OFF key first and wait for 2 seconds before releasing MIN/▼ key.
3. The meter goes through the power-up sequence before coming to measurement mode.
4. The “LO” indicator will blink for every 2 seconds, indicating that the auto power-off feature is disabled.

The “LO” indicator will blink, indicating that the auto power-off feature is disabled

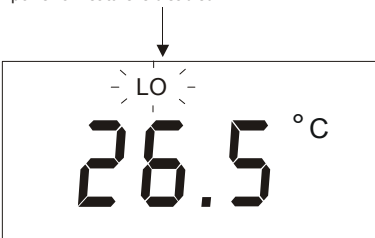

NOTE: When battery is low, the “LO” indicator will blink faster at every 1 second.

5. Once the meter is switched off and subsequently switched on again, the auto power-off feature will be enabled.

NOTE: Under default operation (when auto power-off feature is enabled), the appearance of “LO” indicator permanently on the display means the battery power is low. Once a new battery is installed, the “LO” indicator will disappear.

6. PROBE CARE AND MAINTENANCE

For best results, always clean the temperature probe with clean tissue paper after measurement to keep the probe in good working condition. Wash the probe thoroughly with tap water if necessary to wash off any residue. Should there be any thin oil film sticking on the probe, wash with mild detergent or soap and warm water. Rinse probe thoroughly under running water. Blot it dry and clean off with clean tissue.

To remove the probe, simply hold firmly onto the probe's plastic holder and pull the connector out of the meter's socket. Store both the probe and meter into its original packaging when not in use.

7. TROUBLESHOOTING

Problem	Cause	Solution
No display when turned on	a) Batteries not in place.	a) Insert batteries. b) Re-insert batteries in correct polarity.
"oPEn" display on LCD	a) Probe not connected	a) Make sure probe is firmly connected.
"Ur" or "Or" display on LCD	a) Measurement over (Or) or Under (Ur) range	a) Ensure temperature taken is within meter's specification.
"LO" annunciator appear steady or flashing at 1 sec interval in the LCD	a) Low battery	a) Replace batteries with fresh ones.
"LO" annunciator appear flashing at 2 sec interval in the LCD	a) Auto-off is disabled	a) Power the unit off and power on to enable the Auto-off feature
Unstable reading	a) Electrode not deep enough in sample b) Dirty connector c) Broken probe d) External "noises" or induction caused by nearby electrical motor	a) Place probe deeper in sample. b) Clean probe connector. c) Replace electrode. d) Remove or switch off interfering motor.
Slow response	a) Dirty probe	a) Clean probe

8. SPECIFICATIONS OF TEMP SERIES

Model	Temp 4 and 5 (Thermistor)	Temp 6 (RTD)
Temperature Range	-40.0 to 125.0 °C; -40.0 to 257 °F	-200.0 to 850.0 °C; -328.0 to 1562 °F
Resolution	0.1 °C/0.1 °F	0.1 °C/0.1 °F (for -99.9 to 199.9 °C /-99.9 to 391.9 °F); 1 °C/1 °F (range < -99.9 °C/-99.9 °F & range > 199.9 °C/391.9 °F)
Accuracy	± 0.2 °C/0.4 °F	± 0.2 °C/0.4 °F
Hold Function	"HO"	
Auto Power Off	Selectable; Default factory setting, 17 minutes after last operation	
Low Battery Indication	"LO"	
Error Message Display	"Or", "Ur", "oPEn"	
Display	Single Custom LCD	
Operating Temperature	0 to 50 °C	
Power Requirements	4 x "AAA" Alkaline Batteries	
Battery Life	> 200 hours	
Dimensions / Weight	Meter: 14 x 7 x 3.5 cm / 200g Boxed: 24 x 17 x 8 cm / 550 g	

9. ACCESSORIES

Item Description	Eutech Instruments Order Code	Oakton Instruments Ordering Code
Temp 4 Meter	EC-TEMP4/00	35626-00
General Purpose Probe	~	93824-00
Temp 5 Meter with probe	EC-TEMP5/01	35626-10
100K Thermistor Temperature probe	EC-TEM5TEM01P	35626-50
Temp 6 Meter (with probe)	EC-TEMP6/01	~
Temp 6 Meter only	EC-TEMP6/00B	35626-20
3 wire RTD Pt100 Temperature probe	EC-TEM6TEM01R	08117-70
Replacement rubber boot	~	35606-80
Replacement AAA batteries	~	09376-00

10. WARRANTY & RETURN OF ITEMS

This meter is supplied with a warranty against significant deviations in material and workmanship for a period of **THREE** years from date of purchase whereas probe with a **SIX**-month warranty.

If repair or adjustment is necessary and has not been the result of abuse or misuse within the designated period, please return – freight pre-paid – and correction will be made without charge. Eutech Instruments/ Oakton Instruments will determine if the product problem is due to deviations or customer misuse.

Out of warranty products will be repaired on a charged basis.

Exclusions

The warranty on your instrument shall not apply to defects resulting from:

- Improper or inadequate maintenance by customer
- Unauthorised modification or misuse
- Operation outside of the environment specifications of the products

11. RETURN OF ITEMS

Authorisation must be obtained from our Customer Service Department or authorised distributor before returning items for any reason. A "Return Goods Authorisation" (RGA) form is available through our authorised distributor. Please include data regarding the reason the items are to be returned. For your protection, items must be carefully packed to prevent damage in shipment and insured against possible damage or loss. Eutech Instruments/ Oakton Instruments will not be responsible for damage resulting from careless or insufficient packing. A restocking charge will be made on all unauthorised returns.

NOTE: Eutech Instruments Pte Ltd/ Oakton Instruments reserves the right to make improvements in design, construction, and appearance of products without notice.

NOTES

For more information on Eutech Instruments/ Oakton Instruments' products, contact your nearest distributor or visit our website listed below:

Oakton Instruments

P.O Box 5136,
Vernon Hills, IL60061, USA
Tel (in U.S.): 888-462-5866
Tel (outside U.S.) 1-847-549-7600

Fax: (1) 847-247-2984
E-mail: info@4oakton.com
www.4oakton.com

8 jgfh]Vi HX'Vm

NOVA-TECH
INTERNATIONAL

800 Rockmead Dr Ste 102 • Houston, TX 77339-2496
Tel: (281) 359-8538 • Toll Free Tel: (866) 433-6682
Fax: (281) 359-0084 • Toll Free Fax: (866) 433-6684
sales@novatech-usa.com • www.novatech-usa.com