

2400T & 2400T-PLUS SERIES Installation, Operation and Maintenance Manual

NOVA-TECH
INTERNATIONAL

800 Rockmead Dr Ste 102 • Houston, TX 77339-2496
Tel: (281) 359-8538 • Toll Free Tel: (866) 433-6682
Fax: (281) 359-0084 • Toll Free Fax: (866) 433-6684
sales@novatech-usa.com • www.novatech-usa.com

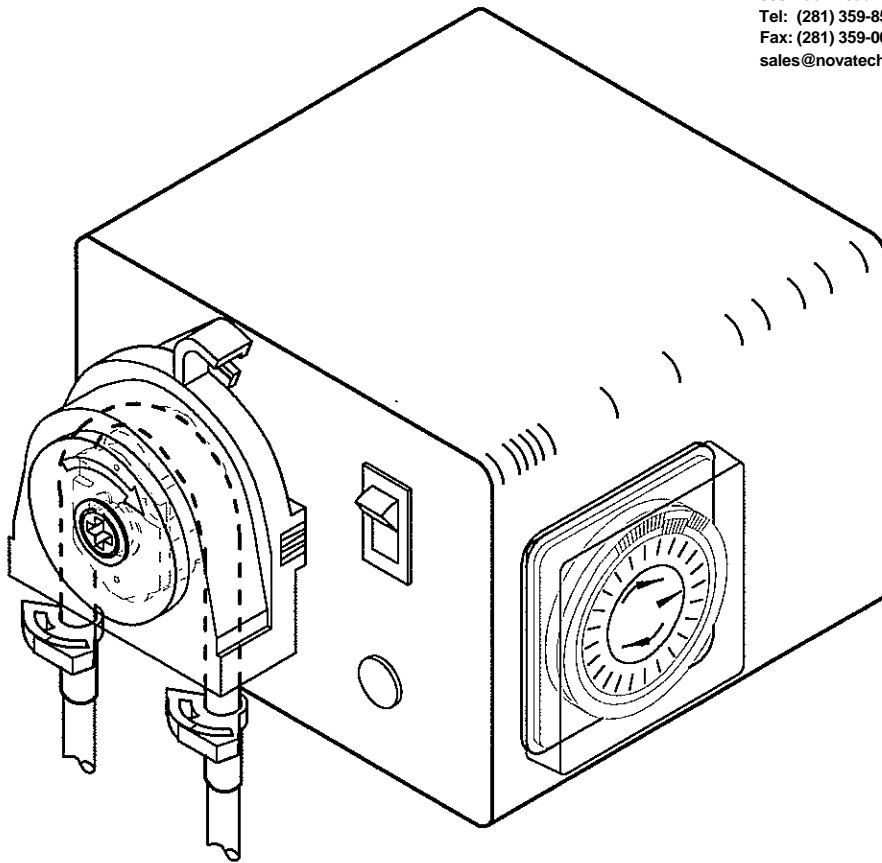

LIQUID CHEMICAL SOLUTION & SLURRY METERING PUMPS WITH 24-HOUR TIMER

READ ALL WARNINGS CAREFULLY BEFORE
INSTALLING PUMP

PUMP DATA/SPECIFICATIONS

Fill in information from pump data label

Series: _____
 Serial #: _____
 Model #: _____
 Nominal output: _____
 Maximum pressure: _____
 Volts/Hz/Amps/Phase: _____
 KOPkit® #: _____
 Tubing material/size: _____

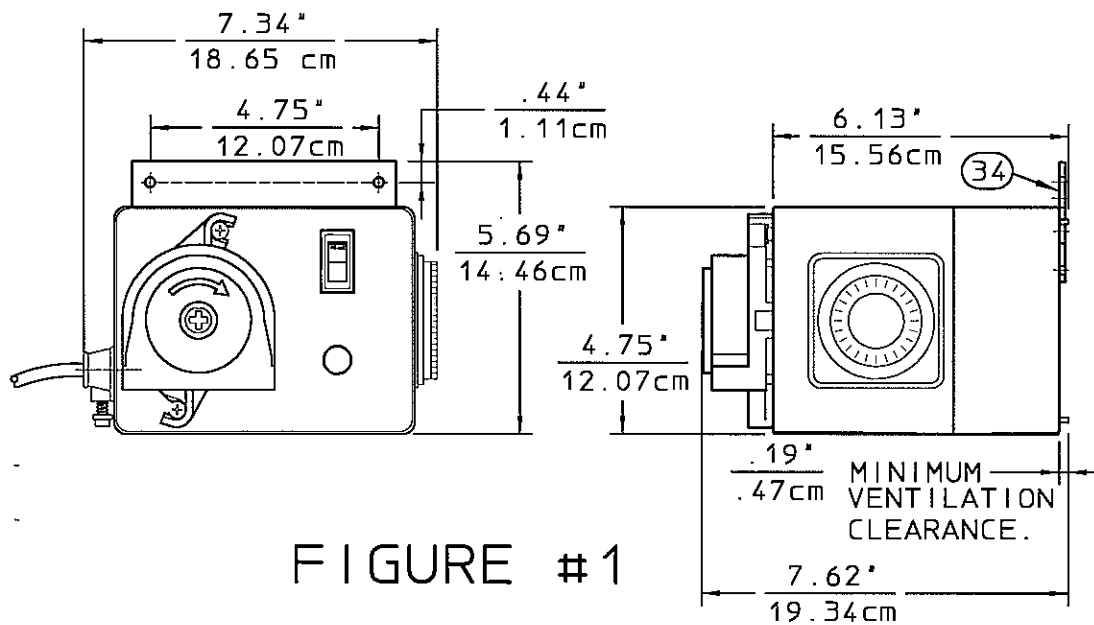

WARRANTY:

The manufacturer warrants its equipment of its manufacture to be free of defects in material or workmanship. Liability under this policy extends to eighteen(18) months from the date of purchase or one(1) year from date of installation or whichever comes first. The manufacturer's liability is limited to repair or replacement of any device or part, which is returned, prepaid, to the factory and which is proven defective upon examination. This warranty does not include installation or repair costs and in no event shall the manufacturer's liability exceed the selling price of such part.

The manufacturer disclaims all liability for damage to its products through improper installation, maintenance, use or attempts to operate such products beyond their functional capacity, intentionally or otherwise, or any unauthorized repair. Replaceable elastomeric parts are expendable and are not covered by any warranty either expressed or implied. The manufacturer is not responsible for consequential or other damages, injuries or expense incurred through use of its products.

The above warranty is in lieu of any other warranty, either expressed or implied. The manufacturer makes no warranty of fitness or merchantability. No agent of ours is authorized to make any warranty other than the above.

For warranty and service matters contact the seller or:

Pulsafeeder, inc
 Standard Pump Operations
 27101 Airport Road
 Punta Gorda, Florida 33982

European Union
 PULSAFEEDER, INC.
 STEIGAR 24
 NL 1351 AB ALMERE
 NETHERLANDS

TABLE of CONTENTS

SAFETY INSTRUCTIONS	PAGE 3
TECHNICAL SPECIFICATIONS	PAGE 4
INSTALLATION	PAGE 4
OPERATION	PAGE 5
MAINTENANCE	PAGE 6
STD. ASSEMBLY DRAWING/WIRE DIAGRAM/PARTS LIST	PAGE 8
CE ASSEMBLY DRAWING/WIRE DIAGRAM/PARTS LIST	PAGE 10
DIGITAL TIMER PROGRAMMING INSTRUCTIONS	PAGE 12

SAFETY INSTRUCTIONS

READ ALL INSTRUCTIONS PRIOR TO USE

- *** **⚠ DANGER**: Secure chemicals & metering pumps, making them inaccessible to children & pets.
- *** **DO NOT PUMP FLAMMABLE LIQUIDS.**
- *** To reduce risk of electric shock before maintenance, repair, or moving pump, disconnect power cord and de-pressurize system and drain chemical.
- *** Do not cut the plug or ground lug off the electrical cord. Consult a licensed electrician for proper installation.
- ** **⚠ WARNING**: Always wear protective clothing, including gloves and safety glasses, when working on or near chemical metering pumps.
- ** Inspect tubing regularly for cracking or deterioration and replace as necessary. **(Always wear protective clothing and safety glasses when inspecting tubing.)**
- ** Use **CAUTION** to keep fingers away from rotating parts.
- ** If pump is exposed to direct sunlight, use a U.V. resistant tubing.
- ** Follow directions and warnings provided from the chemical manufacturer. The user is responsible for determining the chemical compatibility with the chemical feed pump.
- ** Make sure the voltage on the pump data label matches the installation voltage. If pump fails to start, check line voltage.
- ** Consult with local health officials and/or qualified water conditioning specialists when treating potable water.
- ** Always depressurize system prior to installation or disconnecting the metering pump tubing.
- ** If injection point is lower than the chemical tank and pump, install an anti-siphon valve.
- ** **DO NOT MODIFY PUMP.** This poses a potentially dangerous situation and will void the warranty.
- * **⚠ CAUTION**: All pumps are factory tested with water. Remove tubing and thoroughly dry if the chemical being pumped will react with water. (i.e. sulfuric acid)
- * Hand tighten plastic connections(**Do not use wrench**).
- * Consult licensed plumber and electrician before installation to conform to local codes.
- * **NOTE:** For accurate volume output, pump must be calibrated under all operating conditions.

Technical specifications

- Feed Rate:.....Refer to Data Label.
 * Model 2400T:.....2.5-gal/day, 9.5 LPD .39 LPH.
 * Model 2400T-PLUS.....same as 2400T

‘*’ Denotes approximate feed rates. Actual output must be measured at time of application.

- Dimensions:.....See figure #1 on page #2.
 Electrical rating:.....Refer to name plate.
 Maximum Ambient Temperature:.....104°F(40°C).
 Maximum Pressure:.....25-PSI, 1.76-kPa.

Materials Of Construction

- Pump Head:.....Chemical Resistant Resin.
 Pump Head Tubing:.....Special Silicone Tubing.
 Injection Fitting(standard w/ check valve):.....PVC.
 Strainer:.....FPP.
 Suction / Discharge Tubing:.....Polyethylene.
 Pump Housing:.....Chemical Resistant Resin.

INSTALLATION

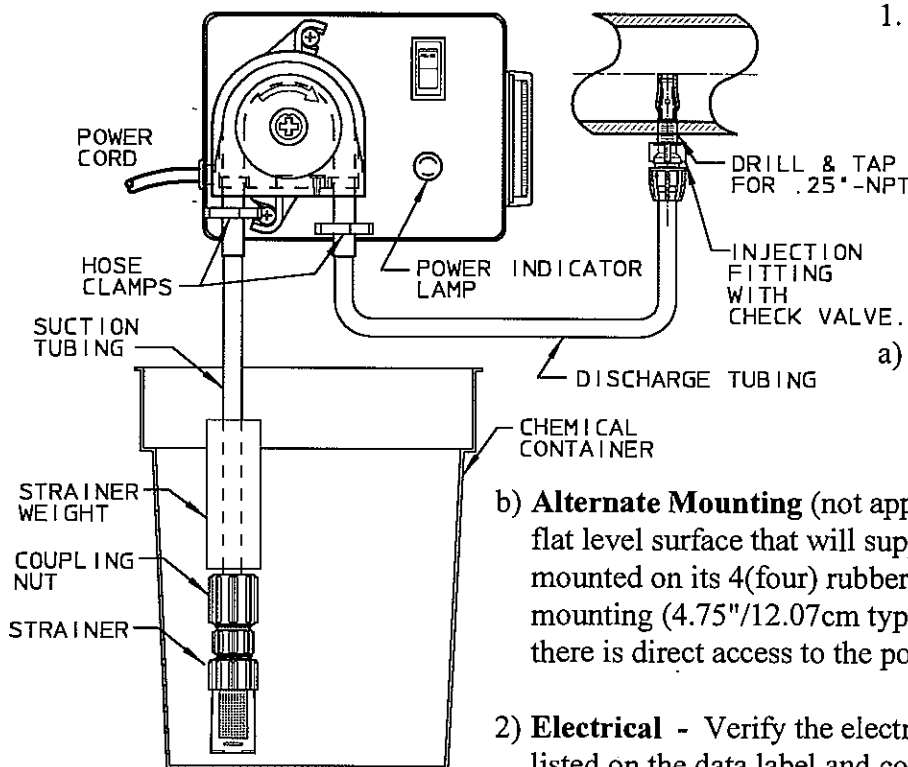

FIGURE #2

1. **Mounting:** Locate the feeder so there is direct access to the power cord plug. **CAUTION:** DO NOT POSITION SO THAT COOLING VENTS IN THE REAR OF THE CASE ARE OBSTRUCTED, .19"(4.7mm) minimum ventilation clearance is required.

a) For 'CE' approved units the bracket mount(Item#34) must be utilized for stationary mounting of pump.

b) **Alternate Mounting** (not approved for 'CE'): Set the feeder on a flat level surface that will support its weight. The feeder should be mounted on its 4(four) rubber feet, or use keyholes on back for wall mounting (4.75"/12.07cm typical spacing). Locate the feeder so there is direct access to the power cord plug.

2) **Electrical** - Verify the electrical requirements for the pump as listed on the data label and connect to an appropriate electrical source in compliance with local codes for the specific application.

3) **Injection Fitting** - Relieve system pressure in the drain piping run where the injection fitting is to be installed. See figure #2. **The injection fitting must not be installed in a dead end pipe or a deeply recessed tee. It should be installed so as to place the tip at the center of the fluid stream.** The injection fitting has .25"-NPT. threads. If necessary drill a .44" (1.1cm.)-hole and using care not to tap to deeply, tap for .25"-N.P.T. Apply Teflon tape to the injection fitting threads and install into piping system. **DO NOT REMOVE THE PLASTIC SLEEVE ON THE TIP OF THE FITTING.** It is a functional part. **CAUTION:** **Inspect piping system and eliminate piping cross-connections to prevent feeding chemical to areas not needing treatment.**

4) **Suction & Discharge Tubing** - Take the 15-ft(4.5m). length of .25"-dia. tubing included, measure & cut the lengths needed to run from the pump head to the injection fitting, and to the chemical tank(Fig.#2). Cut the tubing ends square.

INSTALLATION(cont.)

5) Refer to maintenance section to install the pump head tubing.

6) **Connect discharge tubing to the injection fitting** - Remove the injection coupling nut; slide it over the end of the tubing. Push the end of the tubing onto the injection fitting. Note: Immerse tubing in hot water to soften prior to pushing on fitting. Turn on and tighten the coupling nut firmly, **Hand tighten only do not use wrenches.**

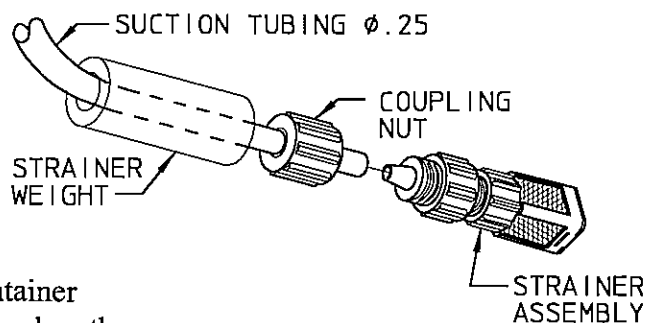

7) **Connect suction tubing to strainer** - Install strainer so it is off the bottom of the chemical container 1-2 inches(2.5-5cm)see figure #2. Measure suction tubing length required. Cut tubing end square and install on suction fitting of the pump. **Hand tighten only do not use wrenches.**

FIGURE #3

OPERATION

1) Fill the chemical tank with the chemical you will feed.

2) TO PRIME FEEDER.

- The feeder is supplied with a prime switch.
- To prime the pump, push prime switch and hold until tubing becomes completely filled or it is possible to make the pump run by pressing the timer tripper button adjacent to the indicator arrow. When the button is pushed in, the pump will run; when pulled back out, the pump will stop.



PRIME SWITCH

3) TO SET TIMER for 2400T(Mechanical Timer)

- Rotate dial clockwise until correct "time of day" is aligned with time of day pointer.
- 24-hour program provides 96 settings in nominal 15-minute increments.
- Push one tab in towards the center for each "on" time you wish.

NOTE : Each tab depressed will run pump for approximately 15-minutes. Pump output must be measured under actual feed conditions.

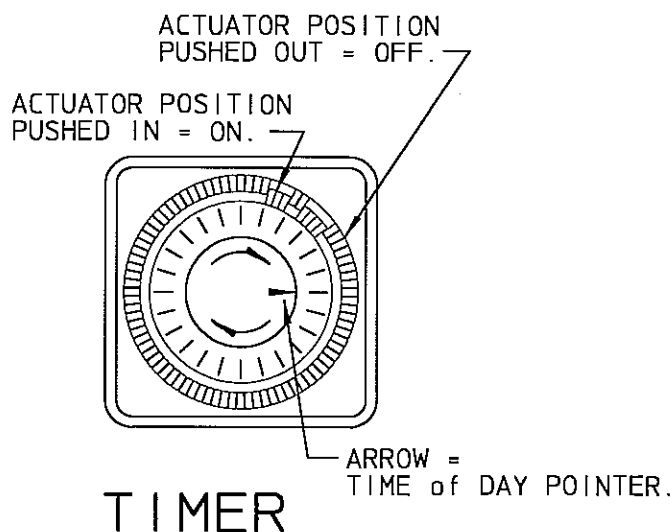

TO SET TIMER FOR 2400T-PLUS (Digital Timer) see pages 12 thru 14.

Pumps carrying the 'ETL Sanitation' seal are listed for swimming pools, spas and hot tubs, and when proper materials are selected, are capable of handling but not limited to the following chemical solutions:

12% ALUMINUM SULPHATE,	5% SODIUM CARBONATE,
2% CALCIUM HYPOCHLORITE,	10% SODIUM HYDROXIDE,
10% HYDROCHLORIC ACID,	12.5% SODIUM HYPOCHLORITE

MAINTENANCE

NOTE: NO USER SERVICEABLE COMPONENTS INSIDE ENCLOSURE. SHOULD THE POWER SUPPLY CORD BECOME DAMAGED, IT MUST BE REPLACED BY PULSAFEEDER or IT'S REPRESENTATIVES or A SIMILARLY QUALIFIED PERSON IN ORDER TO AVOID A HAZARD.

⚠ DANGER: Do not attempt to feed chemicals without consulting your chemical feeder dealer or chemical supplier.

Filling the chemical tank - To avoid running out of chemical, follow a regular schedule of monitoring chemical supply. Also inspect and clean the strainer by flushing with a compatible liquid, as needed.

⚠ CAUTION: Inspect peristaltic tubing frequently & replace when deterioration becomes apparent. Peristaltic tubing will eventually wear & break if neglected. This occurrence will cause chemical spillage & potential for personal injury or damage to equipment. If a potential hazardous or corrosive chemical is handled, take precautions to prevent personal injury & damage in the event of tubing failure. Refer to chemical manufacturer's recommendations with regard to safety & handling precautions. Always wear protective clothing & safety glasses when working near chemical feed systems.

⚠ CAUTION: Do not expose pump head tubing to pressure over 25-PSIG(1.76-kPa).

Tubing Inspection: Inspect all tubing regularly & replace it if deteriorating. Use the following instructions to replace the pump head tubing.

Replacing pump head tubing:

⚠ CAUTION: Wear protective gloves, goggles, & other adequate protection for the chemical hazard. Before replacing the pump head, remove chemical from tubing as follows: Remove strainer from chemical tank, then run feeder until all chemical is removed from the tubing.

- 1) Remove the hose clamps from the tubing at the pump head(twist clamp to disengage teeth).
- 2) Pull the suction & discharge tubing from the pump head tubing.
- 3) Rotate the pump head counter-clockwise(see arrows in figure #5) to disengage from the collars on the feeder cover. DO NOT REMOVE or LOOSEN COLLAR SCREWS.

- 4) Grasp the tabs on the back cover of the pump head & pull straight out to remove. (See Figure #7)

⚠ CAUTION: Do not lose the bearing from the center hole in the back cover. It's not necessary to remove the spider & bearing from the housing.

- 5) Remove the old tubing & retaining collars from the pump head(See Figure #6).
- 6) Position the spider about as shown in figure #6. Then put the retaining collar on the pump head tubing as shown, and position the collar in the pump head with the open end facing outward.

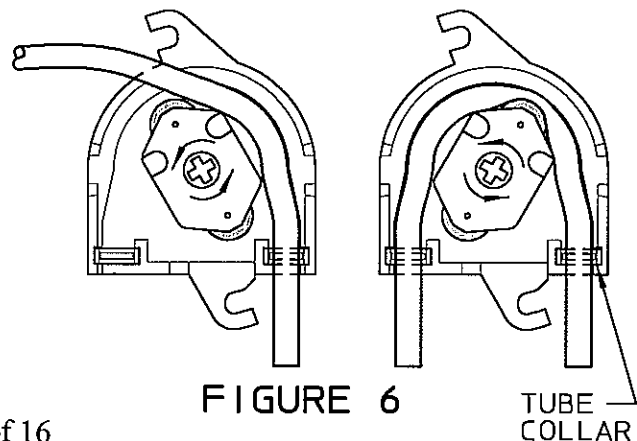
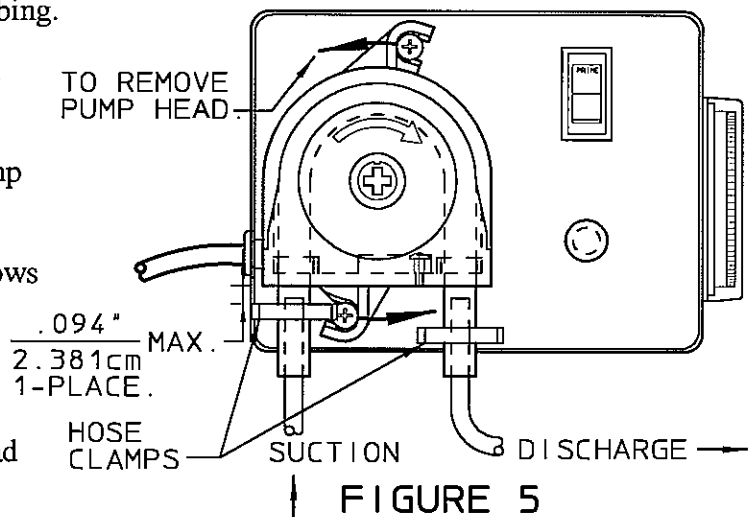

MAINTENANCE(CONT.)

- 7) While rotating the spider counter-clockwise, push the tubing into the housing to center over the roller as shown in figure #6.
- 8) Replace the back cover on the pump head. **Be sure it fits tightly against & flush with the housing(Fig.#7).**
- 9) Slide the pump head onto the motor drive shaft and turn it clockwise to lock onto the 2(two) locking collars.
- 10) Push the suction tubing & discharge tubing into the pump head tubing(Figure #5 & 8). Do not push tubing past retaining collars. Install a hose clamp to hold the tubing together. Use pliers to squeeze the clamp tightly. **CAUTION:** Hose clamps must be tightened securely to prevent leakage, except when using .13"-I.D. norprene tubing with barb fittings(no clamps).

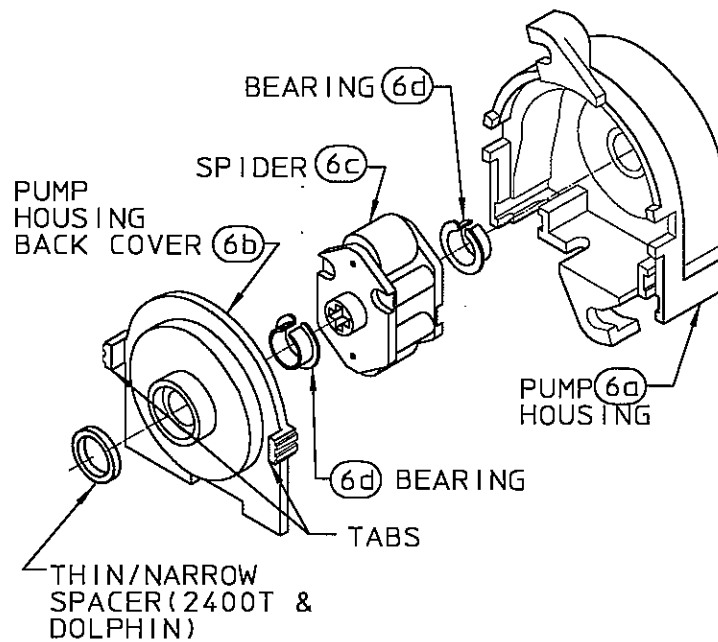

FIGURE 7

STANDARD 2400T AND 2400T-PLUS PARTS LIST/ BILL OF MATERIALS

ITEM	DESCRIPTION	PART#	QTY
1	PUMP HOUSING(2400T)	U0819144	1
	" (2400T-PLUS)	U0819145	
2	MOTOR 5 rpm 120v/60Hz	U0818602	1
	" 5 rpm 230v/50/60Hz	U0818603	
3	FAN	U0818564	1
4	PUMP COVER	U0819143	1
5	TIMER 24h 120vAC/60hz(MECH.)	U0817952	1
	" 24h 230vAC/60hz(MECH.)	U0818652	
	" 24h 230vAC/50hz(MECH.)	U0818574	
5a	TIMER 120vAC/50-60hz(DIGITAL)	U0818740	1
	" 230vAC/50-60hz(DIGITAL)	NC960004-000	
6*	PUMP HEAD AS'Y(NO-PAD)	U8800753	1
7	SWITCH/PRIME	U0818061	1
8	INDICATOR LAMP 115v	U0818018	1
	" 230v	U0818647	
9	POWER CORD AS'Y. 120v	U0817433	1
	" 230v	U0817434	
10	STRAIN RELIEF	L9900700-000	1
11	WIRE CLIP	U0814047	1
12			
13	COLLAR, PERI HEAD	U0819132	2
14	SCREW,#10-32 x .688"lg.	U0817942	3
15	SCREW,#8-18x1.0"lg.	L9806200-188	6
16	SCREW,#6-32 x .25"lg.	U0812955	1
17	LABEL, DATA	---	1
19	LEAD AS'Y.w2 TERM.(BLACK) 7'	U0818557	1
20	LEAD AS'Y. (BLK. or WHT.) 6'	U0818556	1
21	LEAD AS'Y. (YELLOW) 4.5'	U0818084	2
22	LEAD AS'Y. (WHITE) 4.5'	U0818085	1
23	LEAD AS'Y.w/2 TERM. (WHT)4.5'	U0818086	2
24	WIRE NUT	U0501653	2
25+	SILICON TUBE ϕ .31" ASY	U0817131	1
26	HOSE CLAMP	U0817742	2
27	TUBE COLLAR(ϕ .31"-TUBE)	U0817122	REF
29	INJECTION FITTING	U8800712	1
30*	STRAINER AS'Y	J60552	1
31	STRAINER WEIGHT	L9906700-000	REF
32	TUBING 1/4" x 15'	U8800431	1

- + - INCLUDES TWO COLLARS(ITEM #27).
- * - INCLUDES WEIGHT(ITEM #31).

2400T/2400T-PLUS ASSEMBLY

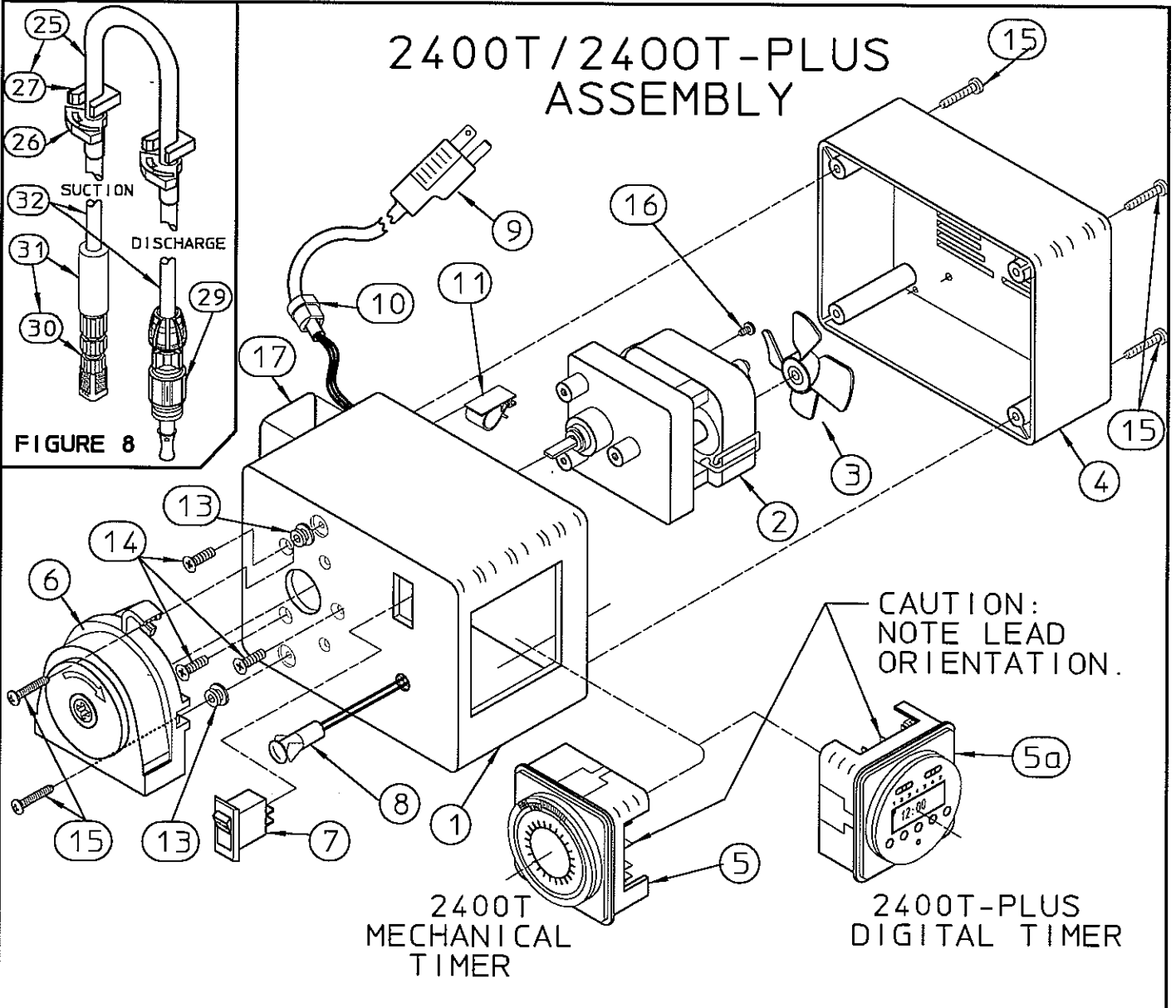

WIRING DIAGRAM

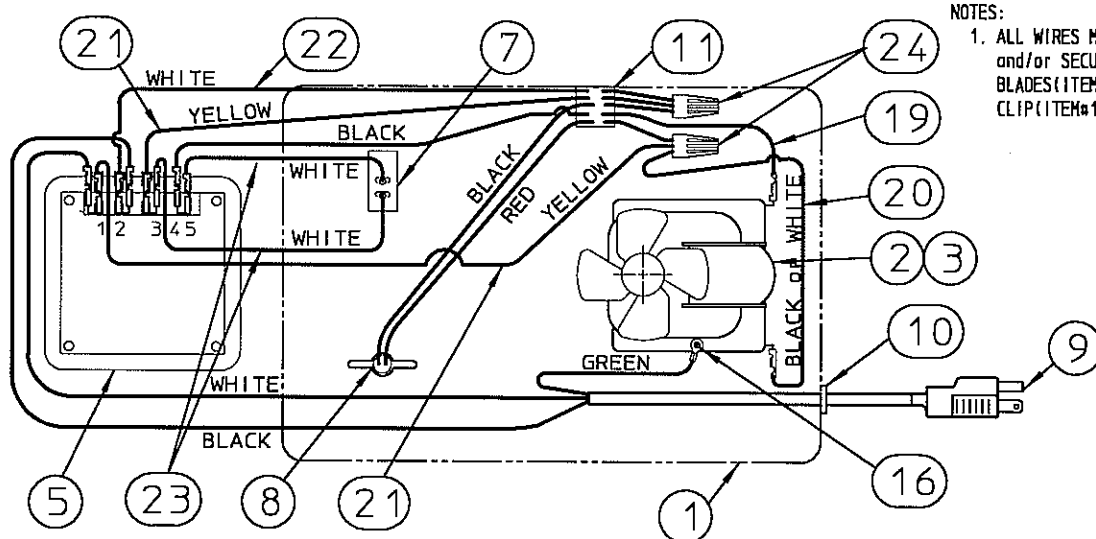

FOR CE PUMPS

2400T/2400T-PLUS PARTS LIST/BILL OF MATERIAL

ITEM	DESCRIPTION	PART#	QTY
1	PUMP HOUSING(2400T) CE	U0819214	1
	PUMP HOUSING(2400T-PLUS) CE	U0819215	
2	MOTOR 5 rmp 230v/50/60Hz	U0818603	1
3	FAN	U0818564	1
4	PUMP COVER (2400T) CE	U0819146	1
5	TIMER 24h 230vAC/50hz(MECH.)	U0818574	1
5a	TIMER 230vAC/50-60hz(DIGITAL)	NC960004-000	
6*	PUMP HEAD AS'Y(NO-PAD)	U8800753	1
7	SWITCH/PRIME CE	U0819207	1
8	INDICATOR LAMP 230v CE	U0819198	1
9	POWER CORD AS'Y. 230v CE	U0819191	1
10	STRAIN RELIEF CE	J35762	1
11	WIRE CLIP	U0814047	1
12			
13	COLLAR, PERI HEAD	U0819132	2
14	SCREW,#10-32 x .688"lg.	U0817942	3
15	SCREW,#8-18x1.0"lg.	L9806200-188	6
16	SCREW,#6-32 x .25"lg.	U0812955	1
17	LABEL, DATA	---	1
19	Y-LEAD AS'Y. 4'-BROWN	U0819210	1
20	Y-LEAD AS'Y. 4'-BLUE	U0819211	1
21	Y-LEAD AS'Y. 2'-BLUE MALE BARREL	U0819209	1
22	Y-LEAD AS'Y. 2'-BROWN FEMALE BARREL	U0819208	1
23	Y-LEAD AS'Y. 5'-BROWN	U0819212	1
24	Y-LEAD AS'Y. 2'-BROWN	U0819213	1
25+	SILICON TUBE ϕ .31" ASY	U0817131	1
26	HOSE CLAMP	U0817742	2
27	TUBE COLLAR(ϕ .31"-TUBE)	U0817122	REF
29	INJECTION FITTING	U8800712	1
30*	STRAINER AS'Y	J60552	1
31	STRAINER WEIGHT	L9906700-000	REF
32	TUBING 1/4" x 15'	U8800431	1
34	BRACKET, PUMP MNTG. CE	U0819178	1
35	SCREW, #10-32 x .25"-lg.	U0811205	2

- + - INCLUDES TWO COLLARS(ITEM #27).
- * - INCLUDES WEIGHT(ITEM #31).

FOR CE PUMPS 2400T/2400T-PLUS ASSEMBLY

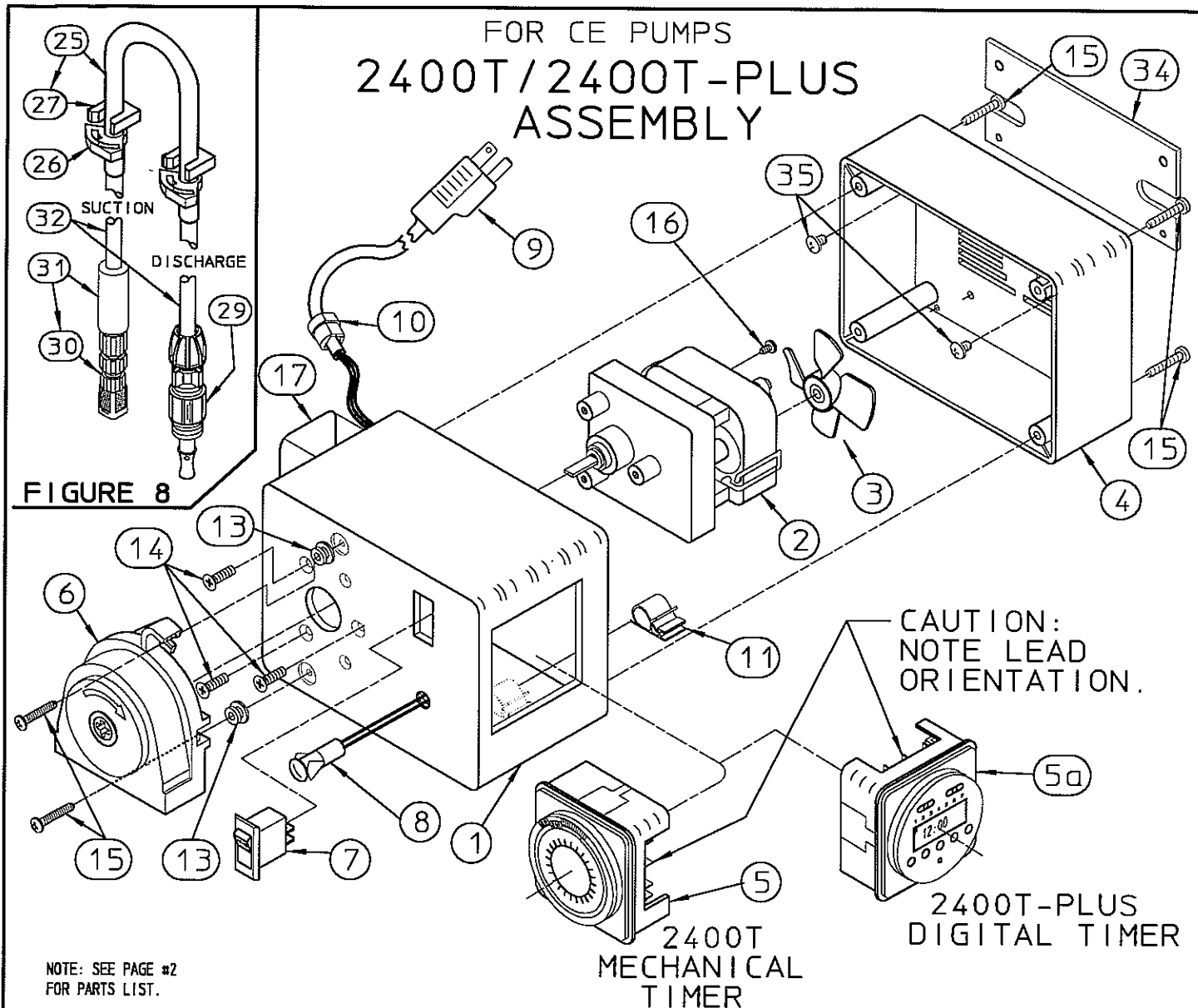

FOR CE PUMPS WIRING DIAGRAM

NOTES: 1. ALL WIRES MUST BE PLACED CLEAR and/or SECURED, TO CLEAR FAN BLADES (ITEM#3) BY USING WIRE CLIP (ITEM#11).

2. US COLORS WIRING EURO COLORS

WHITE	= NEUTRAL	= BLUE
BLACK	= LINE	= BROWN
GREEN	= EARTH	= GREEN w/ YELLOW

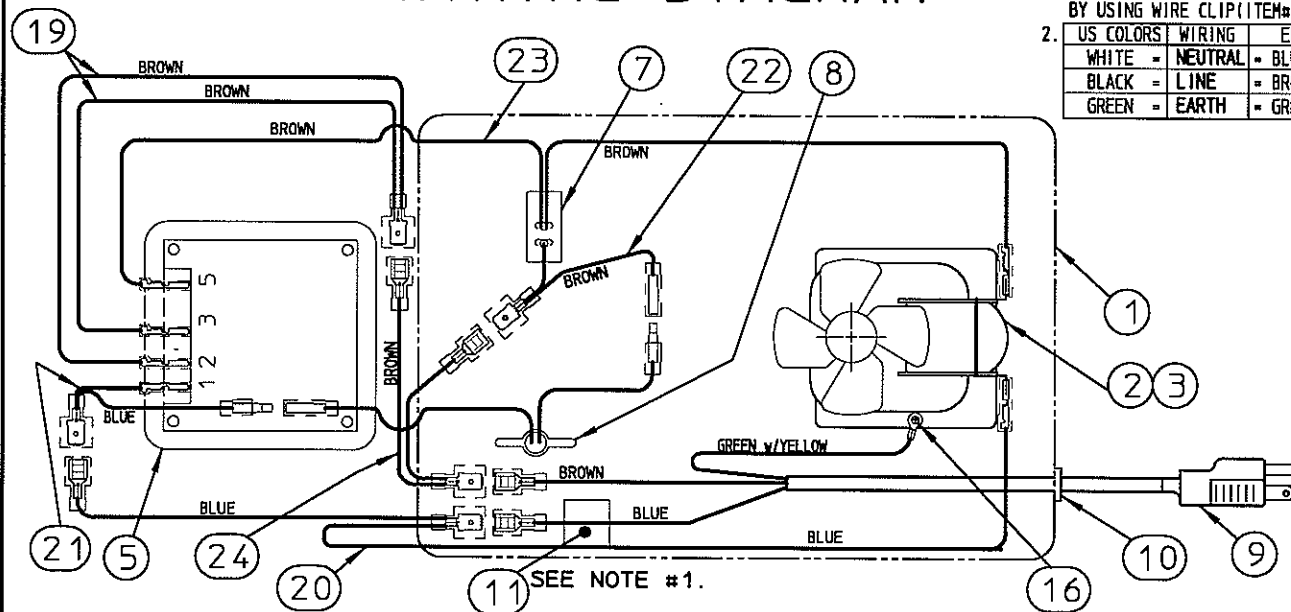

PUMP TIMER PROGRAMMING INSTRUCTIONS

1. **Read all instructions first.**
2. When programming or re-programming, use the program work sheet to set up the desired program before entering the steps into the timer. Seeing the program on paper may avoid errors and will make it easier to put the correct steps into the timer.
3. When re-programming, it is always best to use the 'R' reset button and re-program all cycles.
4. Avoid program sequences which overlap another program. Programs which start while another program is in the 'ON' sequence will not activate.
5. An 'EEE' on the screen indicates an error in program sequence. To correct, push the 'R' reset button; reset time of day and day of week; then re-program.
6. **CAUTION** Do not attempt to re-program while the timer is in the 'ON' sequence unless the 'R' recessed reset button is pressed first and all sequences are reprogrammed.
7. **CAUTION** Do not press the 'P' button while in the 'time of day' (⌚) set mode. This may cause an error in the time keeping program which will cause hours:minutes to count in seconds. If this condition occurs, slide the programming selector switch to the '⌚' position, press the 'P' button and the 'h' button at the same time, then use the 'h' button to correct the time. When the time of day is corrected, slide the programming selector switch back to the 'RUN' position.
8. **CAUTION** Do not reset the time of day during an active cycle. Wait to reset during an 'OFF' cycle or use 'R' reset button and follow the complete instruction from the beginning.
9. All programming errors may be corrected by moving the right side button to the 'RUN' position and depressing the 'R' reset button. This will clear all memory, both 'time of day' and all programs. All desired programs and 'time of day' must be re-entered. Begin again at step #1.

Setting Time of Day:

1. With the programming selector switch in 'RUN' position, push recessed reset button, 'R' (0:00 will flash on the display).
2. Slide the programming selector switch to the left to the '⌚' **time of day** position, (12:00 will appear on the display).
 - 2a. Use the '1..7' button to set **day of week** using '1' as Monday. Put the day indicator '▲' under the day of week.
 - 2b. Use the 'h' button to set **hour**. 'P' will appear on the left side of the display to indicate P.M.
 - 2c. Use the 'm' button to set **minutes**.
3. Slide the programming selector switch to center, 'RUN' position to check time setting. The colon ':' will flash. Be certain that minutes do not change with each flash of the colon. If this condition occurs, an error has been made. Begin again at step #1.

AS SEEN IN AUTOMATIC RUN CONDITION
AT 2:00 PM WITH PUMP RUNNING

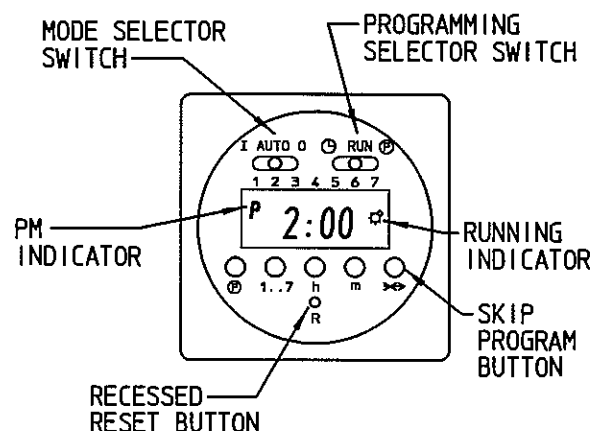

NOTE: 1 Setting the time in the above sequence will clear all programs, reset the programs as required. (Skip step #1 to correct the time setting without clearing programs).

PUMP TIMER PROGRAMMING INSTRUCTIONS(cont.)

NOTE 2. Check the clock after completion of the time setting procedure. If the clock changes minutes with each flash of the colon, an error has occurred. To correct this condition, slide the programming selector switch to the '⌚' position. Push the 'Ⓟ' button and the 'h' button at the same time, then push the 'h' button to advance the hours to the correct time of day. Slide the programming selector switch back to the 'RUN' position.

Setting Programs: (refer to program worksheet (page 4) for guidance)

4. Slide programming selector switch right to program 'Ⓟ' position. (Screen will show "12:00 1 ⌚") This indicates that you are setting the first event which is the 'ON' time for first cycle.
- 5a. Use the '1..7' button to set the desired day(or days) of the week. Put the day indicator '▲' under the day or days) you want to run this program. Pressing the '1..7' button once will put the day indicator '▲' under Sunday (7), pressing again will move the day indicator '▲' to Monday (1). Continue pressing the button to advance day by day to Saturday (6). Press again to get multiple day programs.
Once = All weekdays (1 thru 5)
Twice = Weekend only (6 and 7)
3 Times = Every day except Sunday (1 thru 6)
4 Times = Every day (1 thru 7)
- 5b. Use the 'h' button to set **hour**, remember to set the time in A.M. or P.M. as required.
- 5c. Use the 'm' button to set **minutes**.
6. Push the program button 'Ⓟ' to enter the data and set 'ON' time. The display will change to '12:00 2' ready for you to set 'OFF' time for first program.
- 7a. Use the '1..7' button to set the day or days of the week for the 'OFF' cycle (refer to 5a sequence). Day or days should match the day or days used in previous 'ON' cycle setting.
- 7b. Set 'OFF' time for first program using the 'h' and 'm' buttons.
8. After setting time to desired 'OFF' time, press the 'Ⓟ' button. This completes Program 1. '12:00 3 ⌚' will appear on the display ready to set the 'ON' time for next program.
- 9a. If further programs are desired, continue setting program using Steps #5 thru #8.
- 9b. If programming is complete, slide the program selector switch back to the 'RUN' position. All programs are now active.
10. To review program settings slide program selector switch to the 'Ⓟ' position. The display will show 'xx:xx 1 ⌚' indicating the first 'ON' cycle, day and time. Press the 'Ⓟ' button again and the display will show 'xx:xx 2' the first 'OFF' cycle day and time. Continue pressing the 'Ⓟ' button to step thru the 'ON' and 'OFF' cycles of the rest of the program. After cycle 8 'xx:xx 8' is passed the display will return to the first cycle. The program selector switch may be returned to the 'RUN' position at anytime during review.

Running the Pump:

11. Position the mode selector switch ('I', 'AUTO', 'O') to the position desired.
Position 'I' = Pump will run continuously, regardless of the program.
Position 'AUTO' = Pump will follow the program sequence.
Position 'O' = Pump will always remain off. Regardless of the program.
12. Skip cycle button '↔' may be used when you want to skip all program sequences programmed for the next day. Press the '↔' button once, the '↔' will appear in the lower right corner of the display. This will stop all program cycles from running the next calendar day (the day indicator '▲' will flash during the day which is being skipped).

PROGRAM WORKSHEET

CAUTION: SET TIME OF DAY PRIOR TO PROGRAMMING

PROGRAM	DAY (or DAYS)						
	1	2	3	4	5	6	7
1 ON 1 ☐							
1 OFF 2							
2 ON 3 ☐							
2 OFF 4							
3 ON 5 ☐							
3 OFF 6							
4 ON 7 ☐							
4 OFF 8							
5 ON 9 ☐							
5 OFF 10							
6 ON 11 ☐							
6 OFF 12							
7 ON 13 ☐							
7 OFF 14							
8 ON 15 ☐							
8 OFF 16							

AS SEEN IN AUTOMATIC RUN CONDITION
AT 2:00 PM WITH PUMP RUNNING

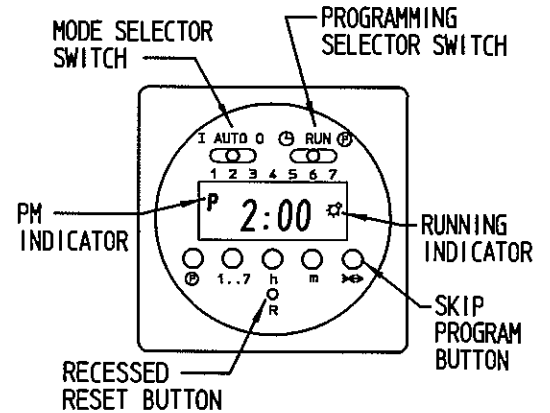

AS SEEN
TO SET ON TIME

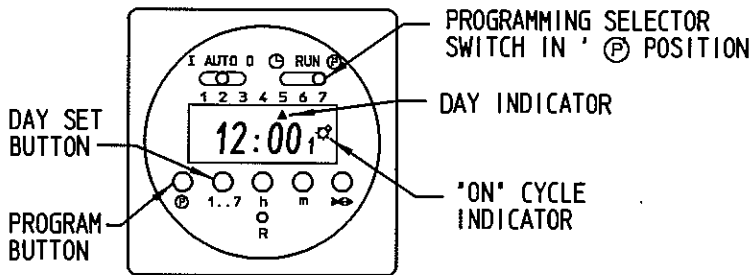

AS SEEN
TO SET OFF TIME

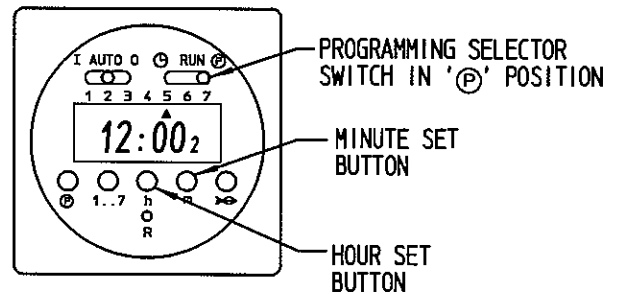

TO SET DAY OF WEEK, PRESS '1...7' BUTTON TO MOVE DAY INDICATOR 'Δ' TO DAY DESIRED (or DAYS). NOTE: ANY INDIVIDUAL DAY IS AVAILABLE, MULTIPLE DAY PROGRAMS ARE LIMITED TO THOSE SHOWN BELOW. SEE 'SETTING PROGRAM', STEP 5A.

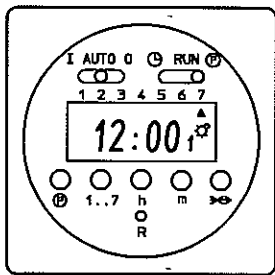

RUN SUNDAY

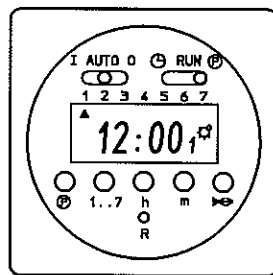

RUN MONDAY

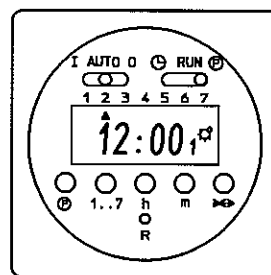

RUN TUESDAY

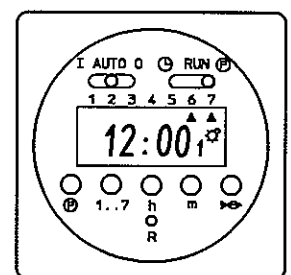

RUN SATURDAY & SUNDAY

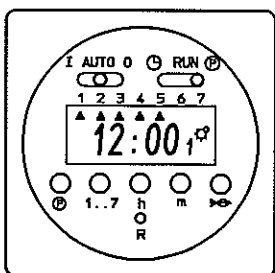

RUN ALL WEEK DAYS

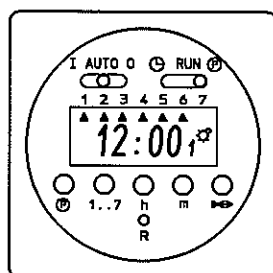

RUN EVERY DAY
EXCEPT SUNDAY

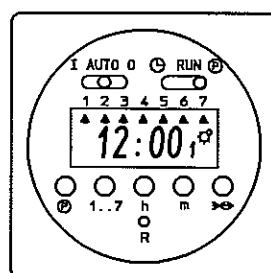

RUN EVERY DAY

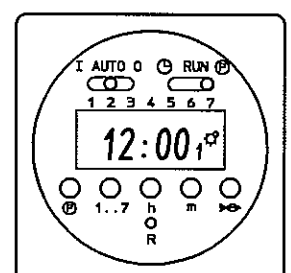

NO DAYS! WILL NOT
RUN THIS PROGRAM

