

# MINIMIX LABORATORY MIXER

Model MLM4

## OWNER'S MANUAL

**NOVA-TECH**  
INTERNATIONAL

800 Rockmead Dr Ste 102 • Houston, TX 77339-2112  
Tel: (281) 359-8538 • Toll Free Tel: (866) 433-6682  
Fax: (281) 359-0084 • Toll Free Fax: (866) 433-6684  
sales@novatech-usa.com • www.novatech-usa.com

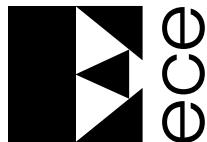

EC Engineering

# Table of Contents

Packing list

Safety precautions

<b>1. Introduction .....</b>	<b>1.1</b>
<b>2. Equipment description .....</b>	<b>2.1</b>
Main components .....	2.1
Mixer unit .....	2.1
Jar assembly .....	2.1
Power supply .....	2.2
Carrying case .....	2.2
<b>3. Jar test procedures .....</b>	<b>3.1</b>
<b>4. Maintenance .....</b>	<b>4.1</b>
General .....	4.1
Cleaning .....	4.1
Lubrication .....	4.1
Fuse replacement .....	4.1
Tools .....	4.1
<b>5. Specifications .....</b>	<b>5.1</b>
Unit .....	5.1
Basic features .....	5.1
Dimensions .....	5.1
Weights .....	5.1
Materials of construction .....	5.1
Illustration showing main components .....	Follows Page 1.1

Rev 26 Nov 03

## Packing list

The items listed below should be included in the Minimix shipping carton. Please check that all items are present and undamaged, and contact ECE or your dealer if there is a problem.

- Minimix mixer unit.
- Sample container (jar) assembly, with 4 compartments.
- Five each: 50 mL beaker, 5 mL syringe, 1 mL syringe, threaded adapter, stopcock, cap, tubing adapter, tubing.
- Plug-in 115VAC or 230VAC to 12VDC wall transformer with cord.
- Foam-lined carrying case.
- Owner's manual.

### ***Serial number***

Each Minimix has a unique four-digit serial number. This can be found on the back of the mixer unit, immediately above the power jack.

## Safety precautions

Please read the entire manual before attempting to unpack, set up, or operate the equipment and pay attention to all the warnings, cautions and notes. Failure to do so may result in injury to the operator or damage to the equipment.

1. The Minimix mixer unit is designed to operate from a 12 volt DC power source. The system is supplied with a wall transformer power supply unit which provides 12V DC from either a 115V or a 230V AC outlet (as specified at the time of ordering). If an alternative power source is used, be sure that the mixer unit receives only 12V DC, with positive to the center pin of the jack.
2. The Minimix operates on low voltage DC power and is therefore very safe electrically. However, take care to avoid submerging the unit or subjecting it to unnecessary amounts of water - this can damage internal components or interfere with their operation. If water does enter the unit, immediately disconnect the equipment from the power supply and leave it to drain and dry out completely.
3. Do not hold the paddles while they are turning, or in any other way try to stop them from rotating. This could cause injury or damage the drive mechanism.
4. The power supply to the unit is protected by a 1 amp fuse. Repeated failure of this fuse indicates a faulty electrical condition and the equipment should be checked by a qualified electrician. Do not replace the fuse with one of a higher rating.

# 1. Introduction

The so-called jar test is an old water treatment test procedure, first introduced in the 1930s. It has remained essentially unchanged since then, although there have been various refinements such as increased mixing speeds and the use of square jars instead of cylindrical beakers.

As basic as the jar test may be, it remains one of the best methods of assessing and optimizing the various processes and options available for treatment of potable and other types of water. Properly done, it can provide a great deal of information during all phases of a treatment system's development - initial process screening and development, equipment sizing, operational optimization, and evaluation of potential alternative treatment processes. All this can be achieved at relatively little cost, and without the need for a great deal of high-tech knowledge and expertise.

However, unlike most analytical procedures used in the water supply industry, there is no standardization of jar testing procedures and the results are almost always open to different interpretations and conclusions. Therefore, a great deal of thought and care, as well as more than a little experience, is essential if the jar test procedure is to achieve its full potential.

Equipment for conducting jar tests has been available for a long time, but most of the available units tend to be bulky, heavy, and subject to various operating problems. EC Engineering offers several jar testing systems, each intended for a different purpose. The Minimix is specifically designed for very small size, light weight, portability, ease of operation, and low cost.

It is not the intent of this manual to discuss in detail all the various planning, objectives, calculations, procedures, and other considerations that are involved in conducting a jar test; this information is available from many different sources. Rather, the intent is to describe the aspects of the procedures that are specific to the Minimix.

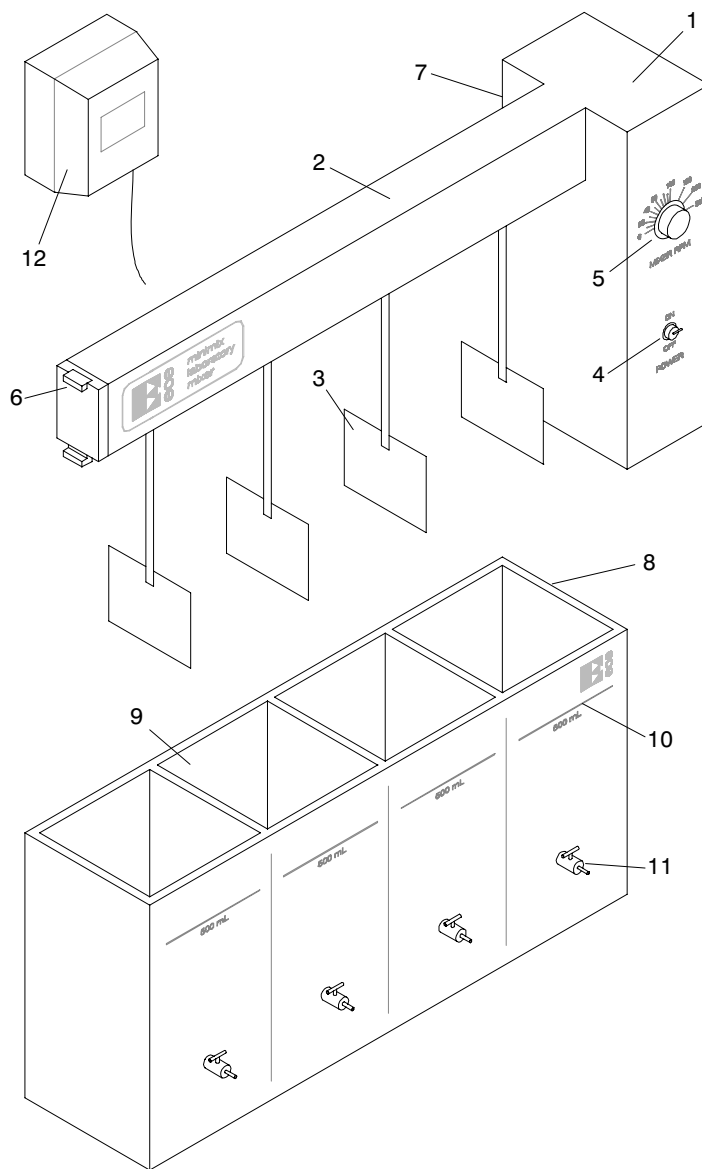

- |   |                          |    |                               |
|---|--------------------------|----|-------------------------------|
| 1 | MAIN HOUSING             | 7  | POWER JACK (ON BACK OF UNIT)  |
| 2 | DRIVE SYSTEM HOUSING     | 8  | JAR ASSEMBLY                  |
| 3 | PADDLES                  | 9  | 500 mL SAMPLE COMPARTMENTS    |
| 4 | POWER ON/OFF SWITCH      | 10 | GRADUATION MARKS              |
| 5 | MOTOR SPEED CONTROL DIAL | 11 | SAMPLING STOPCOCKS            |
| 6 | LATCHING SYSTEM          | 12 | 120VAC/12VDC WALL TRANSFORMER |



**EC Engineering**

6223 - 186 Street, Edmonton, Alberta, Canada T5T 2T3  
 Phone 780.487.0249 Fax 780.487.6883 www.ecengineering.net

**MINIMIX LABORATORY MIXER  
 MAIN COMPONENTS**

## 2. Equipment description

### ***Main components***

The illustration shows the main features of the Minimix system. It has two main components - the mixer unit, and the integrated four-compartment jar assembly. The system also includes a plug-in wall transformer to supply the 12V DC power used by the mixer unit, and a padded carrying case for storing and transporting the equipment.

### ***Mixer unit***

The mixer unit is made up of two main parts:

- **Main housing.** This enclosure contains the mixer drive motor; its coupling to the paddle drive shaft; speed control circuit board; power on/off switch; and speed adjustment control. The housing also has a power jack on the rear (for connection to a 12V DC power source) and two alignment pins that engage corresponding holes in the jar assembly. Access to the inside of the housing is by removing the four screws holding the end panel on the right side of the housing.
- **Drive system housing.** The basic structure consists of an aluminum housing with rear cover plate. It also contains two aluminum end blocks with bearings for the main drive shaft; a bearing for each of the four paddle shafts; a latching system to lock the mixer unit to the jar assembly; and a third alignment pin on the left end. The four paddle shafts are coupled to the main drive shaft by nylon miter gears.

### ***Jar assembly***

The jar assembly is constructed from clear acrylic sheet and contains four sample compartments with graduation marks at the 500 mL level. Each jar compartment is supplied with an adapter which threads into the jar wall; a sampling stopcock which attaches to the threaded adapter; a flexible sampling tube with connector; a 50 mL beaker; 1 mL and 5 mL syringes; and a cap that can be used in place of the stopcock when subsurface sampling is not required. One spare of each of the above fittings is also provided. Additional jar assemblies and fittings are available separately.

## **Power supply**

The Minimix can be powered from any 12V DC supply, through the standard power jack on the rear of the main housing. Normally, this power would be provided by the 115VAC or 230VAC<sup>1</sup> plug-in wall transformer supplied with the system.

If the internal fuse blows when a user-supplied transformer (or other power source such as a battery) is connected, the most likely cause is that the polarity is reversed. Be sure that the output plug has the *center pin positive*. A transformer should have a label similar to this:



Many different styles and sizes of power connectors are available in the electronics marketplace. The input power jack on the Minimix is designed to accept a plug with a 2.1 mm inside diameter, 5.5 mm outside diameter, and 12 mm barrel length. Different plugs (such as those that are slightly shorter, or which have a slightly larger inside diameter) will often work well enough if the standard plug cannot be found. Plugs with inside diameters larger than 2.1 mm (2.5 mm is quite common) will usually work satisfactorily if the split in the center pin of the power jack is widened slightly using a small screwdriver or similar tool.

Voltages of up to 16 volts DC can be used with the Minimix.

## **Carrying case**

The Minimix is supplied in a padded, molded plastic carrying case. The case can hold the mixer unit, jar assembly, and power supply with a useful amount of space left over. This space can be used for storage and transportation of other frequently used items such as chemical reagent bottles, dosing syringes, sample containers, or other equipment.

---

<sup>1</sup> The transformer normally supplied for 230 VAC operation has a European style input plug (two round prongs, 4 mm diameter, 18 mm spacing, on a raised hexagonal base). A transformer for use in the UK (three flat pins) is also available.

For other configurations, it will be necessary for the user to supply either a plug style adapter, or a different transformer to suit local conditions. These are easily available nearly everywhere, at very low cost. The transformer should have an output of 12 volts DC (unregulated) at 500 mA (a higher current rating would be OK but is not necessary).

### 3. Jar test procedures

The basic objective of the so-called jar testing procedure is to simulate, as far as is practical, the processes that are being, or might be, used in a full-scale treatment plant. Because there are fundamental differences between batch and continuous flow processes, the jar test does have its limitations. Nevertheless, it can prove very useful as a simple, rapid, and economical means of evaluating how well proposed water treatment processes can be expected to work, and in determining certain process parameters such as chemical dosages and reaction times.

Of course, each situation will be unique, with its own circumstances and objectives. Therefore, only a simplified, general test procedure can be given; this must be modified as required by the specific situation.

Following is a suggested basic jar test procedure.

1. The jar assembly is usually supplied with the threaded adapters already in the sample ports on the front of the jar assembly. If not, insert them and tighten snugly (do not overtighten). These adapters are normally left permanently in position. Depending on whether subsurface sampling is required, attach either a stopcock or cap (both are supplied for each jar compartment) to the threaded adapters. Usually, the stopcocks would be used, together with the supplied tubing adapters and sample tubing.
2. Fill the jars to the 500 mL mark with the water being tested.
3. Lift the locking tab on the left end of the mixer unit, and place the mixer in position on top of the jar assembly. Slide the mixer unit to the left so the alignment pins engage the three guide holes in the jar assembly, then push the locking tab down to lock the mixer and jars together. The whole assembly can now be lifted and moved about as desired.
4. For each of the test stations being used, fill syringes with the appropriate amount of stock chemical (such as alum coagulant and/or polymer).
5. Start the mixer motor and set it to the desired speed on the control panel dial (usually full speed for the coagulant addition stage).
6. Inject the chemicals into the jars. It should be easily possible to dose all jars within one or two seconds of each other. For simulation of the short, high-intensity "flash mixing" often used in coagulant addition, the mixer speed should be reduced after a time corresponding as closely as possible to the actual mixing time that would be used in a full-scale plant. In many cases, this would be almost immediately after coagulant addition.

7. Set the mixer speed to provide the mixing intensity desired for the first flocculation stage. The speed control system is configured so that the dial scale is expanded towards the lower end of the speed range, which allows easier and more accurate adjustments at the low speeds (20 to 100 rpm) where most jar testing work is carried out. The mixer speeds selected by the dial will be somewhat approximate, but will generally be more than accurate enough for most jar test procedures.
8. At the end of the first flocculation time period, adjust the mixer speed. Repeat as appropriate for the number of flocculation stages desired.
9. After completion of the flocculation stages, pull the mixer unit locking tab up, move the mixer slightly to the right so that the alignment pins clear the jars, and lift it out of the jar assembly. Allow the contents of the jars to settle for the desired periods.
10. Carry out observation, sampling, and evaluation procedures as desired.

*Before returning the Minimix to its carrying case, be sure to remove the stopcocks from the jar assembly. If this is not done, the stopcocks and possibly the threaded adapters may be damaged.*

## 4. Maintenance

### ***General***

The Minimix requires very little maintenance, other than cleaning and occasional minor lubrication.

### ***Cleaning***

The unit should be cleaned up immediately after each run, particularly the jars. If solids such as floc are allowed to dry out on component surfaces, they may be much more difficult to remove later. Rinse with clean water, or wipe down with a damp cloth, as appropriate. *Do not use organic solvents such as acetone or alcohol, which may damage plastic surfaces or paint finishes.*

### ***Lubrication***

All bearings in the Minimix are oil-impregnated bronze, and should require lubrication only very occasionally. If the mixer seems rough or noisy, a small amount of light oil can be applied to the paddle shaft bearings.

### ***Fuse replacement***

The electrical system of the Minimix is protected by a 1 amp fuse, located inside the main mixer housing. To replace the fuse, remove the four screws holding the end cover in place. Insert the new fuse and replace the end cover. If the fuse blows repeatedly, have the electrical system checked by a qualified electrician.

### ***Tools***

No special tools are needed for operation and maintenance of the Minimix.

## 5. Specifications

<b>Unit</b>	<b>MLM4</b>
<b>Basic features</b>	
Number of stations	4
Sample volume	500 mL
Sample container (jar) volume	615 mL
Mixer speed range	10 to 300 rpm
Electrical supply (to mixer unit)	12V DC
Maximum current draw	0.3 amp
<b>Dimensions</b>	
Mixer/jar units, assembled	342 x 178 x 76 mm (13.5 x 7.0 x 3.0 in.)
Carrying case	430 x 315 x 140 mm (17.0 x 12.5 x 5.5 in.)
Shipping carton	445 x 345 x 165 mm (17.5 x 13.5 x 6.5 in.)
<b>Weights</b>	
Base unit	1.0 kg (2.2 lb)
Jar module with fittings	0.7 kg (1.6 lb)
Wall transformer and jar accessories	0.4 kg (0.8 lb)
Carrying case	1.4 kg (3.0 lb)
Total for equipment and carrying case	3.5 kg (7.6 lb)
Total shipping weight with carton	3.8 kg (8.4 lb)
<b>Materials of construction</b>	
Mixer unit	Aluminum and PVC, with epoxy paint coating
Paddles and shafts	Stainless steel
Paddle system bearings	Oil-impregnated bronze
Paddle system gears	Nylon
Sample jars	Clear acrylic
Carrying case	Molded polyethylene